

# PB600-1 Repeating Dispenser

Congratulations! You have purchased the finest quality precision fluid measuring device available today. We combine top quality materials with skilled workmanship, ensuring the highest possible performance level of every precision fluid device we manufacture. With proper care and handling, the PB600-1 Repeating Dispenser will provide unsurpassed performance in precision liquid handling year after year.

**Syringes and needles manufactured by Hamilton Company are intended for scientific research and laboratory use only and are not intended for human *in vivo* use.**

The Hamilton PB600-1 Repeating Dispenser is among the most versatile, hand-held, semi-automated dispensers available. The PB600-1 dispenser has virtually unlimited applications when there is a need to deliver liquid volumes of 0.2 to 50  $\mu\text{L}$  repeatedly up to 50 times before refilling. Some typical uses of the PB600-1 include preparing standard solutions, filling microliter trays, feeding cell cultures, spotting TLC plates, dispensing VDRL antigen, human leukocyte locus-A (HLA) tissue typing, and dosing small animals. Industrial applications include lubricating small bearings or parts, applying liquid solder, and dispensing mercury.

## Replacement Parts

Description	Part Number
PB600-1	83700
(1) Screw	16204
(2) Plunger Arm for 700/1700 Series Syringes	15144
(3) Plunger Arm for 1001/1002 Series Syringes	15142
(4) PB600-1 Flange Screw	14704
(5) O-ring	16102
(6) Index Rod	15104
(7) Index Rod E-ring	19661
(8) Friction Plug	15111
(9) Friction Plug Spring	53299-01
(10) PB600-1 Dispenser Button Spring	19603
(11) Friction Plug Set Screw	5518-06
(12) Set Screw	59624-02

*Note: Numbers in parentheses refer to part numbers in Figure 1.*

## Accessories

TLL, LT, and RN Syringes	Part Number
100 $\mu\text{L}$ Disposable Tips, 1000/pk	1108-21
100 $\mu\text{L}$ Disposable Tip Adapter	31330
1 mL Disposable Tip Adapter	31331

## Syringe Installation and Assembly

The PB600-1 is shipped fully assembled (without the syringe). However, the PB600-1 package contains an additional plunger arm for smaller syringe plungers.

The following assembly procedures include numbers enclosed in parentheses that correspond to specific parts of the PB600-1. The exploded view of the PB600-1 (Figure 1) shows the locations of those parts.

1. Remove the flange screw (4), turning counterclockwise, and the O-ring (5) from the PB600-1 assembly (23).
2. With the index rod (6) fully extended, place the glass syringe barrel into the PB600-1 body. With the O-ring in the groove on the flange screw, thread the flange screw into the PB600-1 body. Finger tighten the screw.

**CAUTION: Over-tightening the flange screw may fracture the glass flange on the syringe barrel.**

3. Select plunger arm that will fit the selected syringe (See CAUTION below) and affix it to the index rod with the screw provided (1). Plunger arm (2) is preinstalled at the factory for 700/1700 Series syringes and (3) is for 1001 and 1002 Series syringes.

**CAUTION: DO NOT remove the index rod from the PB600-1 assembly. If the plunger arm is removed, the index rod can be removed from the PB600-1 assembly. When the index rod comes out of the assembly, all other parts (8, 9, 10, and 22) will fall loose. Extensive reassembly is required at this point.**

4. With the index rod (6) fully extended (without the plunger assembly installed), press and release the dispenser button (22). Repeat until the index rod no longer moves (fully engaged).
5. With the index rod fully engaged, install the syringe plunger through the hole in the plunger arm and into the syringe barrel. Adjust the plunger tip to the zero scale mark silk-screened on the syringe. Tighten screws (1, 12).

**CAUTION: Over-tightening the set screw (12) may bend the plunger assembly. Prior to installing any Gastight® syringe plunger assembly into a glass barrel, wet the PTFE plunger tip to provide lubrication between the tip and the inner bore of the syringe barrel. Failure to wet the plunger tip may cause premature tip wear or tip leakage.**

6. Grasp the plunger arm, and fully retract the plunger assembly (as if you were filling the syringe). Then press the dispenser button repeatedly, counting the number of clicks, until the index rod no longer advances. If you pressed the dispenser button less than 50 times, loosen the plunger arm screw and reposition the plunger (away from zero). Retighten the plunger arm screw. Repeat the test until you achieve 50 dispenses. No other adjustments are necessary. Your PB600-1 is ready for use.

**Note: Every time you press the dispenser button, the PB600-1 Repeating Dispenser mechanically advances the syringe plunger 0.047" (based on a 60 mm scale length at full volume). This action advances a fluid column within the syringe 1/50 of the syringe's volume. Therefore, when setting the plunger tip, it is not necessary for the plunger tip to be precisely at the zero mark. What is important is that the plunger advances 50 times.**

## Syringe and Needle Selection

Syringes and needles are not included with the PB600-1 Repeating Dispenser and must be ordered separately. To achieve the maximum performance from your PB600-1 Repeating Dispenser, consider the application, the syringe volume, and the fluid viscosity.

A syringe with a point style 3 (blunt) needle is recommended for dispensing into an open vessel, into microliter trays, or onto flat surfaces. When injecting through rubber septa, it is best to use a point style 2 needle. Most fluids can be effectively handled using either a 22s gauge or 22 gauge needle. Hamilton part numbers for Luer Tip (LT), Removable Needle (RN), standard Cemented Needle (N), Luer Tip Cemented Needle (LTN), and PTFE Luer Lock (TLL) syringes are identified in Table 1. Please note that LT and TLL type syringes do not come with needles.

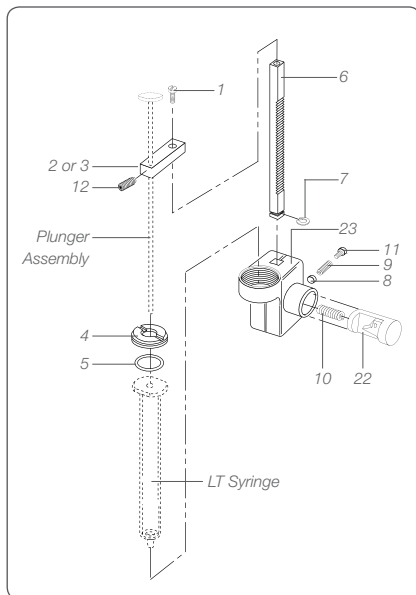

In addition, there are at least two special applications for the PB600-1 repeating dispenser:

**HLA Applications** – Use syringes specified in the parts list with needles designated in parentheses: (22/2”/3). For a “shooting” syringe needle information will appear as follows: (22s/2”/3). The “dropping” syringe needle appears as (22/2”/3).

**VDRL Applications** – Special Luer tip syringes are designed to dispense 1/100 mL or 1/60 mL when installed in the PB600-1. The syringes dispense VDRL antigen emulsion and buffered saline solutions. A special 18-gauge, point style 3 (blunt) bent needle (P/N 90432) and other gauged hypodermic type needles are based on Antigen manufacturers’ VDRL data sheets.

**Table 1: Recommended Hamilton Syringes for Use with the PB600-1**

700 Series Microliter Syringes									
Dispense Volume (µL)	Syringe Volume (µL)	N Point Style 2	N Point Style 3	LTN Point Style 2	LTN Point Style 3	RN Point Style 2	RN Point Style 3	LT	TLL
0.2	10	80300	80365	–	–	80330	–	80301	–
0.5	25	80400	80465	–	–	80430	–	80401	–
1	50	80500	80565	–	–	80530	–	80501	–
2	100	80600	80665	–	–	80630	–	80601	–
5	250	80700	80765	–	–	80730	–	80701	–
10	500	80800	80865	–	–	80830	–	80801	–
1700 and 1000 Gastight Syringes									
Dispense Volume (µL)	Syringe Volume (µL)	N Point Style 2	N Point Style 3	LTN Point Style 2	LTN Point Style 3	RN Point Style 2	RN Point Style 3	LT	TLL
0.2	10	80000	80075	–	–	80030	80065	80001	–
0.5	25	80200	80275	–	–	80230	80265	80201	–
1	50	8 0900	80975	–	–	80930	80965	80901	80920
2	100	81000	81075	–	–	81030	81065	81001	81020
5	250	–	–	81100	81175	81130	81165	81101	81120
10	500	–	–	81217	81216	81230	81265	81201	81220
20	1,000	–	–	81317	81316	81330	81365	81301	81320
50	2,500	–	–	81417	81416	81430	–	81401	81420
VDRL									
Dispense Volume (mL)	Syringe Volume (mL)	N Point Style 2	N Point Style 3	LTN Point Style 2	LTN Point Style 3	RN Point Style 2	RN Point Style 3	LT	TLL
1/100	500	–	–	–	–	–	–	–	81201
1/60	833.5	–	–	–	–	–	–	–	87800

## Filling and Dispensing

To avoid the formation of bubbles, slowly fill the syringe. If bubbles occur, follow one of these steps:

1. Invert the PB600-1 assembly and tap the glass syringe barrel to release the bubbles into the needle end of the syringe. Then press the dispenser button.
2. Manually clear the syringe by freely pushing the plunger of the syringe until the liquid is expelled.

**CAUTION: When filling or manually clearing the installed syringe in the PB600-1, do not engage the dispenser button, as the index rod will jam the syringe plunger.**

**After successfully filling the syringe, firmly press the dispenser button until it bottoms out, before releasing it. Repeat this procedure until the syringe is empty.**

**CAUTION: In actual use, the proper way to hold the PB600-1 is with the thumb on the dispenser button and the index and middle fingers on the opposite side of the body assembly. Do not operate the PB600-1 while holding it in the palm of the hand with the fingers wrapped around the syringe barrel. Excessive pressure on the glass barrel will fracture the syringe at the glass flange, resulting in permanent damage.**

## Cleaning and Maintaining the PB600-1 Repeating Dispenser

Under normal circumstances, the PB600-1 Repeating Dispenser requires little or no maintenance. The dispenser should be operated in a "dry" condition; that is, without any grease, light oils, or graphite lubricants applied to the index rod or dispenser button areas. Occasionally clean the index rod with a stiff brush and acetone to keep the teeth of the index rod free of dust and dirt particles. Do not disassemble the PB600-1 assembly for cleaning.

If the force required to press the dispenser button needs to be modified for a specific application, the friction plug set screw (11) may be adjusted. Do not back out the set screw too far and remove all the force on the friction plug or the unit may not index correctly. Repeat step 6 of the Syringe Installation procedure after making an adjustment to verify that the PB600-1 is functioning properly.

## WARRANTY STATEMENT

Hamilton Company unconditionally guarantees its products to be free of defects in materials and workmanship. Any product that fails due to such a defect will be repaired or replaced at our discretion without cost, provided the device is returned on a Return Materials Authorization (RMA). It is the responsibility of the purchaser to determine the suitability of application and material compatibility of the product based on the published specifications of the product.

## RETURN OF GOODS

Hamilton Company's return and repair policy is written to protect its employees from potentially hazardous materials (e.g., serum, radioactive materials, carcinogenic chemicals, etc.) or any substance that may cause them partial or permanent disability during the inspection or repair process. In returning a product, the customer acknowledges that the product is free from any hazardous materials. Furthermore, the customer assumes responsibility should the returned product prove to be hazardous.

©2018 Hamilton Company. All rights reserved.

All trademarks are owned and/or registered by Hamilton Company in the U.S. and/or other countries.

Lit. No. 69149 Rev. J — 10/2018

**000 «Диаэм»**

Москва  
ул. Магаданская, д. 7, к. 3 ■ тел./факс: (495) 745-0508 ■ sales@dia-m.ru

[www.dia-m.ru](http://www.dia-m.ru)

**С.-Петербург**  
+7 (812) 372-6040  
spb@dia-m.ru

**Новосибирск**  
+7(383) 328-0048  
nsk@dia-m.ru

**Воронеж**  
+7 (473) 232-4412  
vrn@dia-m.ru

**Йошкар-Ола**  
+7 (927) 880-3676  
nba@dia-m.ru

**Красноярск**  
+7(923) 303-0152  
krsk@dia-m.ru

**Казань**  
+7(843) 210-2080  
kazan@dia-m.ru

**Ростов-на-Дону**  
+7 (863) 303-5500  
rnd@dia-m.ru

**Екатеринбург**  
+7 (912) 658-7606  
ekb@dia-m.ru

**Кемерово**  
+7 (923) 158-6753  
kemerovo@dia-m.ru

**Армения**  
+7 (094) 01-0173  
armenia@dia-m.ru

