

Mini-PROTEAN[®] Precast Gels

Instruction Manual and Application Guide



BIO-RAD

Bio-Rad Technical Support

For help and technical advice, please contact the Bio-Rad Technical Support department. In the United States, the Technical Support department is open Monday–Friday, 5:00 AM–5:00 PM, Pacific Time.

Phone: 1-800-424-6723

Fax: 1-510-741-5802

Email: LSG_TechServ_US@bio-rad.com (for U.S. and international customers)

Online technical support and worldwide contact information are available at www.consult.bio-rad.com.

Legal Notices

No part of this publication may be reproduced or transmitted in any form or by any means, electronic or mechanical, including photocopy, recording, or any information storage or retrieval system, without permission in writing from Bio-Rad Laboratories.

Bio-Rad reserves the right to modify its products and services at any time. This user guide is subject to change without notice.

Although prepared to ensure accuracy, Bio-Rad assumes no liability for errors, or for any damages resulting from the application or use of this information.

Coomassie is a trademark of BASF Aktiengesellschaft. Ficoll is a trademark of GE Healthcare Group companies. StrepTactin is a trademark of Institut für Bionalytik GmbH. StrepTactin is covered by German patent application P 19641876.3. Bio-Rad Laboratories, Inc. is licensed by Institut für Bioanalytik GmbH to sell these products for research use only. SYBR is a trademark of Invitrogen Corporation. SYPRO is a trademark of Molecular Probes, Inc. Bio-Rad is licensed to sell SYPRO products for research use only, under U.S. Patent 5,616,502. Tween is a trademark of ICI Americas, Inc.

Contents

Chapter 1: Mini-PROTEAN® Precast Gels	1
1.1 Introduction	1
1.2 Gel Formulations	2
1.3 Comb Configurations	2
1.4 Specifications	2
1.5 Storage Conditions	3
1.6 Important Notes	3
Chapter 2: Setup and Basic Operation	4
2.1 Workflow Overview	4
2.2 Required Materials	5
2.3 Setting Up and Running Mini-PROTEAN Gels in the Mini-PROTEAN® Tetra Cell	5
2.4 Removing the Gel	7
Chapter 3: SDS-PAGE	8
3.1 Introduction	8
3.2 Mini-PROTEAN® TGX™ and Mini-PROTEAN® TGX Stain-Free™ Gels	8
3.3 SDS-PAGE Buffers	10
3.4 Sample Preparation	10
3.5 Running Conditions	10
Chapter 4: Native PAGE	12
4.1 Introduction	12
4.2 Mini-PROTEAN TGX and Mini-PROTEAN TGX Stain-Free Gels	12
4.3 Native PAGE Buffers	13
4.4 Sample Preparation	13
4.5 Running Conditions	13
Chapter 5: Stain-Free System	14
5.1 Introduction	14
5.2 Stain-Free Workflow	15
5.3 Electrophoresis with Mini-PROTEAN TGX Stain-Free Gels	15
5.4 Stain-Free Detection	15

Chapter 6: Peptide Analysis	16
6.1 Introduction.	16
6.2 Mini-PROTEAN Tris-Tricine Gels	16
6.2.1 Gel Composition	16
6.2.2 Gel Selection Guide.	16
6.3 Peptide Analysis Buffers	17
6.4 Sample Preparation.	17
6.5 Running Conditions.	17
Chapter 7: Nondenaturing Nucleic Acid PAGE	18
7.1 Introduction.	18
7.2 Mini-PROTEAN TBE Gels	18
7.2.1 Gel Composition	18
7.2.2 Gel Selection Guide.	18
7.3 Nondenaturing Nucleic Acid PAGE Buffers	19
7.4 Sample Preparation.	19
7.5 Running Conditions.	19
Chapter 8: Denaturing Nucleic Acid PAGE	20
8.1 Introduction.	20
8.2 Mini-PROTEAN TBE-Urea Gels	20
8.2.1 Gel Composition	20
8.2.2 Gel Selection Guide.	20
8.3 Denaturing Nucleic Acid PAGE Buffers	21
8.4 Sample Preparation.	21
8.5 Running Conditions.	21
Chapter 9: 2-D Electrophoresis	22
9.1 Introduction.	22
9.2 Equilibration.	22
9.3 Agarose Overlay	22
9.4 Second-Dimension Electrophoresis.	22

Chapter 10: Detection	23
10.1 SDS-PAGE and Native PAGE Detection	23
10.2 Peptide Gel Staining	24
10.3 TBE Gel Staining	24
10.4 TBE-Urea Gel Staining	24
Chapter 11: Blotting	25
11.1 Introduction	25
11.2 Transfer	25
11.2.1 Transfer Buffers	25
11.2.2 Wet Transfer Using the Mini Trans-Blot® Module	25
11.2.3 Transfer Using the Trans-Blot® Turbo™ System	26
11.2.4 Semi-Dry Transfer Using the Trans-Blot® SD Cell	27
11.3 Total Protein Blot Stains	28
11.4 Immunodetection	28
Chapter 12: Troubleshooting	29
Appendix A: Quick Start Guides	31
SDS-PAGE (Mini-PROTEAN TGX Gels)	32
Native PAGE (Mini-PROTEAN TGX Gels)	33
Peptide Analysis (Mini-PROTEAN Tris-Tricine Gels)	34
Nondenaturing Nucleic Acid PAGE (Mini-PROTEAN TBE Gels)	35
Denaturing Nucleic Acid PAGE (Mini-PROTEAN TBE-Urea Gels)	36
Appendix B: Buffers	37
Appendix C: Related Literature	40
Appendix D: Ordering Information	41

1

Mini-PROTEAN® Precast Gels

1.1 Introduction

Mini-PROTEAN precast gels are 7.2 cm x 8.6 cm gels designed for performing polyacrylamide gel electrophoresis (PAGE) with the Mini-PROTEAN family of vertical electrophoresis cells, which includes the Mini-PROTEAN® Tetra and Mini-PROTEAN® 3 Dodeca™ cells and the discontinued Mini-PROTEAN II and Mini-PROTEAN 3 cells. The Mini Trans-Blot®, Trans-Blot® Turbo™, and Trans-Blot® SD blotting cells and precut membrane sandwiches are also available for blotting applications with these gels.

Features of Mini-PROTEAN precast gels include:

- Outlined and numbered well that simplify sample loading and identification
- Capacity for up to 15 samples per gel
- Bottom-open cassette design for easy gel handling and blotting setup
- Easy-to-open cassette for faster downstream processing
- Reference line at the bottom of the cassette indicates where the run should stop (for optimum resolution across the separation range)
- Excellent staining quality and transfer efficiency
- No gel foot to remove prior to blotting
- Mini-PROTEAN® TGX Stain-Free™ formulations, which enable rapid 5 min gel imaging without staining and destaining

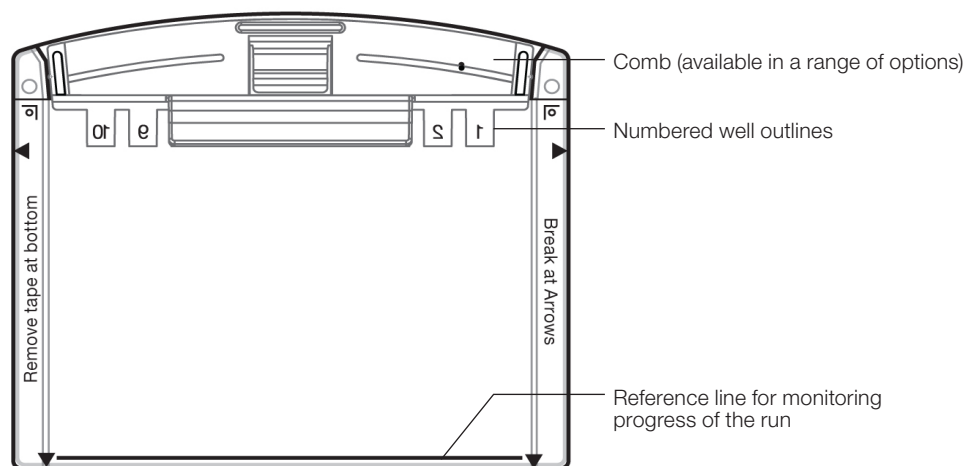

1.2 Gel Formulations

Mini-PROTEAN precast gels are composed of polyacrylamide with a bisacrylamide crosslinker, and they are available in a range of formulations (Table 1.1) and in a selection of single percentages and gradients.

Table 1.1. Mini-PROTEAN precast gel formulations.

Application	Gel Formulation	Sample Buffer	Running Buffer
SDS-PAGE	Mini-PROTEAN TGX™ Mini-PROTEAN TGX Stain-Free	Laemmli	Tris/glycine/SDS
Native PAGE	Mini-PROTEAN TGX Mini-PROTEAN TGX Stain-Free	Native	Tris/glycine
Peptide analysis	Mini-PROTEAN Tris-Tricine	Tricine	Tris/Tricine/SDS
dsDNA separation	Mini-PROTEAN TBE	Nucleic acid	Tris/boric acid/EDTA (TBE)
ssDNA and RNA separation	Mini-PROTEAN TBE-urea	TBE-urea	TBE

1.3 Comb Configurations

Comb Type	Well Volume
10-well	50 µl
10-well	30 µl
12-well	20 µl
15-well	15 µl
8 + 1 well*	30 µl
IPG/prep	7 cm ReadyStrip™ IPG strip (450 µl)

1.4 Specifications

Gel material	Polyacrylamide
Gel dimensions	7.2 x 8.6 cm
Gel thickness	1.0 mm
Resolving gel height	6.2 cm (5.6 cm for 50 µl well)
Cassette dimensions	8.5 x 10 cm
Cassette material	Styrene copolymer
Comb material	Polycarbonate
Running buffer	750 ml for 1–2 gels, 1,000 ml for 3–4 gels (Mini-PROTEAN Tetra cell) 325 ml for 1–2 gels (Mini-PROTEAN II or Mini-PROTEAN 3 cell)

* Multichannel pipet compatible.

1.5 Storage Conditions

Table 1.2. Storage conditions for Mini-PROTEAN precast gels. Store gels flat. Shelf life is from date of manufacture; expiration dates are printed on the packaging.

Storage Temperature	Gel Formulation	Shelf Life
2–8°C	Mini-PROTEAN TGX	12 months
	Mini-PROTEAN TGX Stain-Free	12 months
	Mini-PROTEAN Tris-Tricine	12 weeks
	Mini-PROTEAN TBE	12 weeks
	Mini-PROTEAN TBE-urea	8 weeks

1.6 Important Notes

Use each Mini-PROTEAN precast gel as soon as possible after removing it from the storage pouch.

Improper storage of Mini-PROTEAN precast gels can produce artifacts. Store gels flat and at 2–8°C. Avoid freezing or prolonged storage above 8°C. If your gels have been stored improperly, discard them.

Do not run more than one gel type in the same apparatus at the same time. Different gel percentages and formulations have different conductivities and different run times.

With the Mini-PROTEAN Tetra cell:

- When running 1–2 gels:
 - Use the electrode assembly (with banana plugs), not the companion running module (without banana plugs)
 - Do not place the companion running module in the tank. Doing so generates excessive heat and degrades the quality of the electrophoretic separation
- When running 3–4 gels, use both the electrode assembly and companion running module
- When using voltages >200 V, fill the outer buffer chamber to the 4 gel (800 ml) mark

2

Setup and Basic Operation

2.1 Workflow Overview

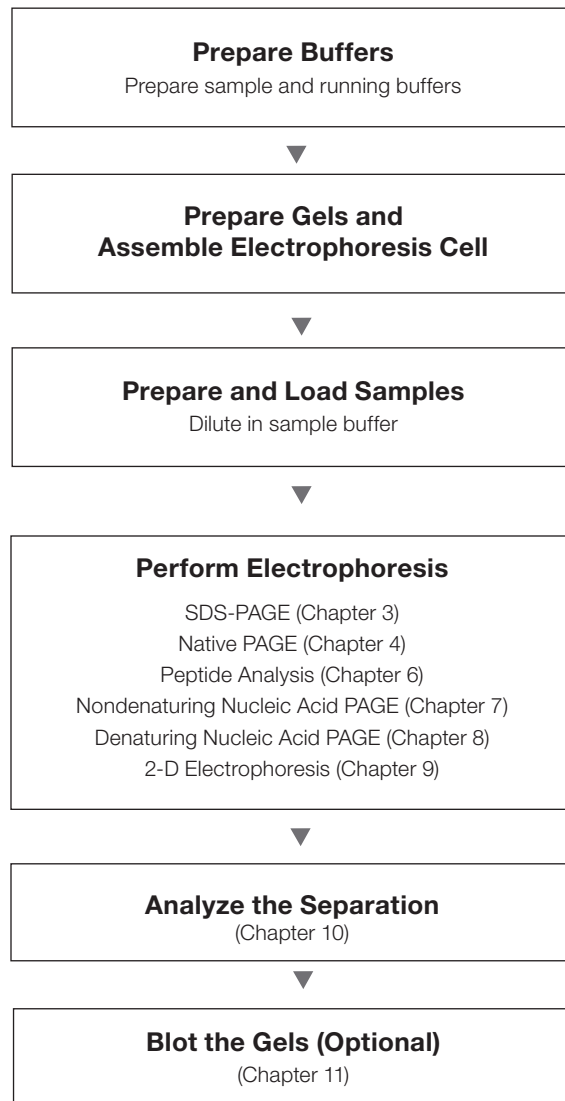

2.2 Required Materials

- Mini-PROTEAN® precast gels
- Mini-PROTEAN® Tetra cell (or Mini-PROTEAN® 3 Dodeca™, Mini-PROTEAN II or Mini-PROTEAN 3 cell)
- PowerPac™ Basic or PowerPac HC power supply (or equivalent); PowerPac HV or PowerPac Universal required for high-voltage applications (>300 V)
- Sample buffer
- Running buffer (750 ml for 1–2 gels; 1,000 ml for 3–4 gels or when running at voltages >200 V)
- Opening lever (catalog #456-0000)

2.3 Setting Up and Running Mini-PROTEAN Gels in the Mini-PROTEAN Tetra Cell

1. Remove the gels from the storage pouch and prepare them for assembly:
 - a. Remove the comb: Position thumb on the indentation (middle of comb) and remove the comb by pulling upward in one smooth motion.
 - b. Remove the tape: Pull gently to remove the green tape from the bottom of the cassette. If necessary, use the opening key or comb to help remove the tape at the corners.
 - c. Rinse the wells: Use a syringe, wash bottle, or disposable transfer pipet to rinse the wells with

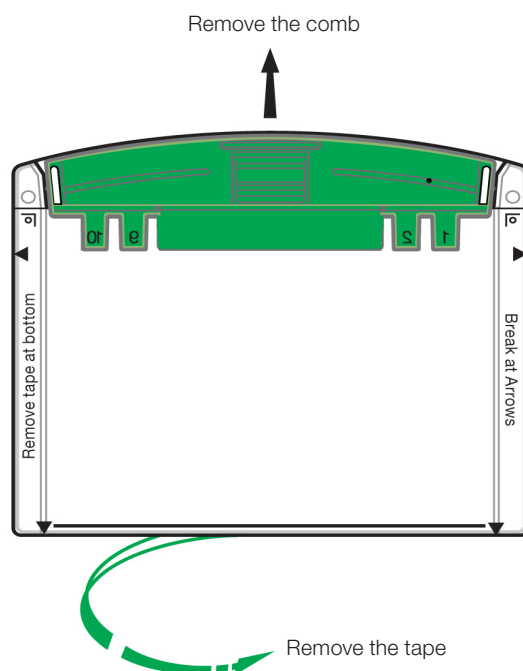

running buffer. Straighten the sides of the wells, if necessary.

2. Set the electrode assembly to the open position on a clean, flat surface (A).
3. Place the gel cassettes into the electrode assembly. Two cassettes are required to create a functioning assembly; when using 1 or 3 gels, use the buffer dam (included with the cell) to complete the assembly.

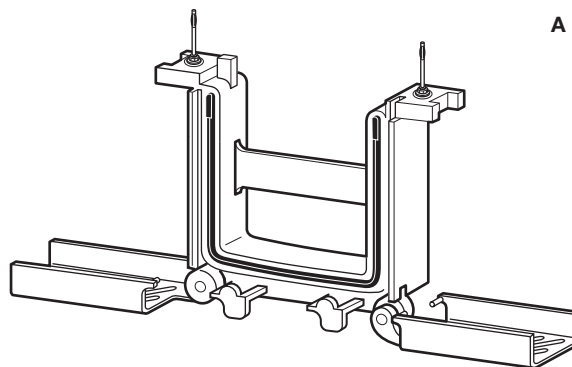

- a. Place the first cassette with the short plate facing inward and so the gel rests at a 30° angle away from the center of the electrode assembly. Make sure the electrode assembly remains balanced and does not tip over.
- b. Place the second gel or buffer dam on the other side of the electrode assembly, again by resting the gel on the supports. The gels rest at 30° angles, one on either side of the electrode assembly, tilting away from the center of the frame (B).

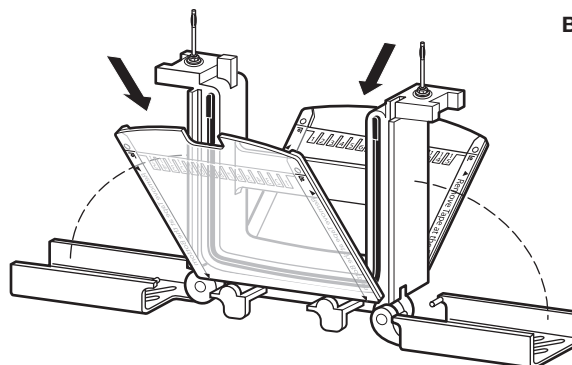

4. Gently push both gels toward each other, making sure that they rest firmly and squarely against the green gasket that is built into the electrode assembly. Align the short plates to ensure the edge sits just below the notch at the top of the green gasket (C).
5. While gently squeezing the gel cassettes (or cassette and buffer dam) against the green gaskets (maintaining constant pressure and with both gels in place), slide the green arms of the clamping frame one at a time over the gels, locking them into place (D,E).
6. The wing clamps of the electrode assembly lift each gel cassette up against the notch in the green gasket, forming a seal. Check again that

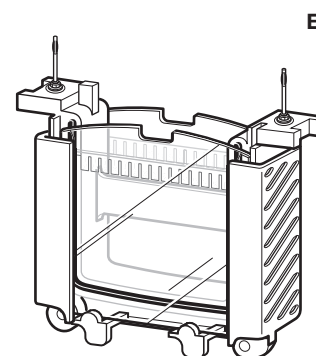
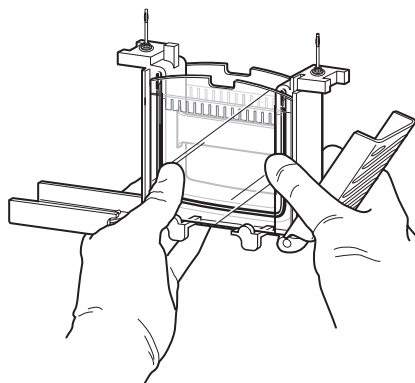
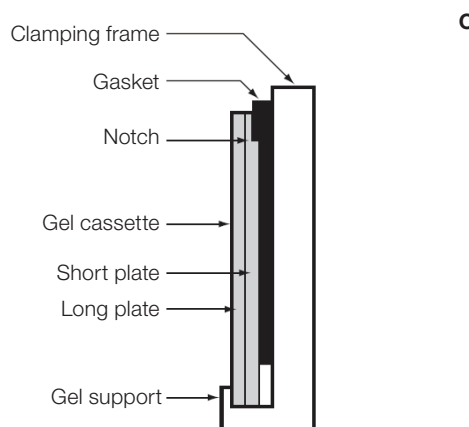

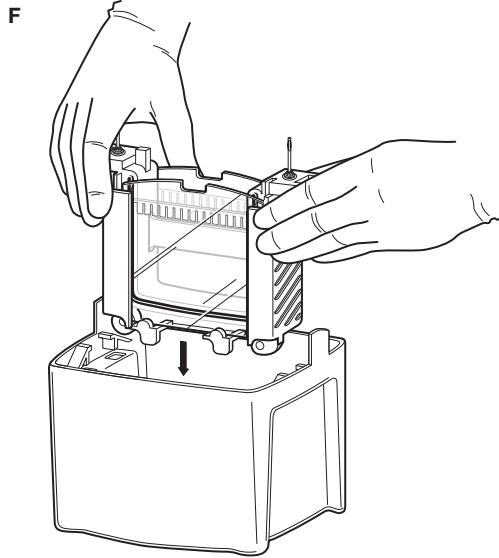

the short plates sit just below the notch at the top of the green gasket (C).

If running more than 2 gels, repeat steps 2–6 with the companion running module.

7. Place the electrophoresis module into the tank (F) and fill the buffer chambers with 1x running buffer:
 - 200 ml in the inner buffer chamber
 - 550 ml (1–2 gels) or 800 ml (3–4 gels, or >200 V) in the outer buffer chamber
8. Wash the sample wells with running buffer (if this was not done earlier).
9. Load samples and run the gels using the running

conditions appropriate to your application. Stop the run when the dye front reaches the reference line imprinted on the bottoms of the cassettes.

2.4 Removing the Gel

1. After electrophoresis is complete, turn off the power supply and disconnect the electrical leads.
2. Remove the lid from the tank and remove the gels from the cell. Pour off and discard the running buffer.
3. To open the cassette, align the arrow on the opening lever with the arrows marked on the cassette and insert the lever between the cassette plates at indicated locations. Apply downward pressure to break each seal. Do not twist the lever.
4. Pull the two plates apart from the top of the cassette, and gently remove the gel.

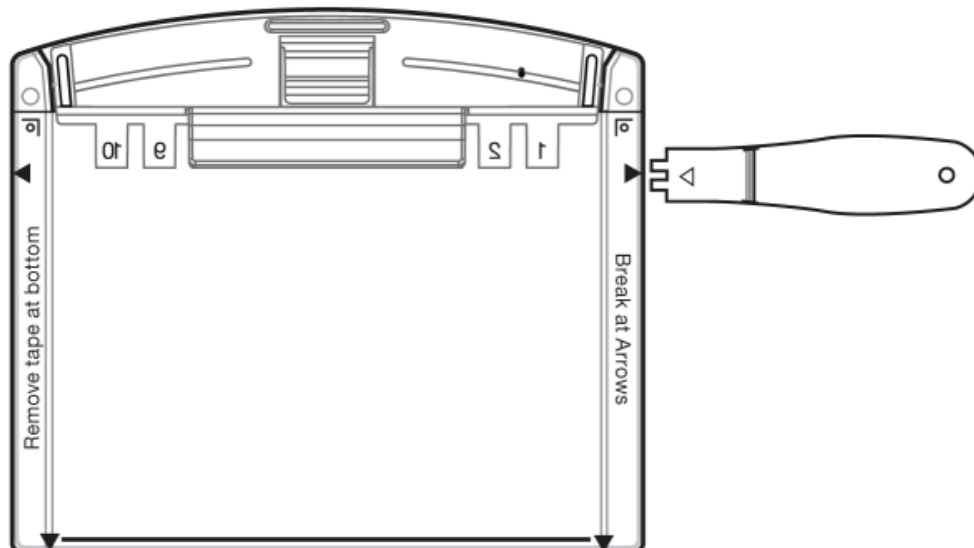

3

SDS-PAGE

3.1 Introduction

Mini-PROTEAN® TGX™ (Tris-Glycine eXtended shelf life) gels provide a versatile system for separating proteins by either molecular weight (SDS-PAGE) or mass-to-charge ratio (native PAGE). (See Chapter 4 for native PAGE applications and protocols.) This versatility is possible because the gels are made without SDS; this allows the sample buffer and running buffer to determine the separation mechanism.

SDS-PAGE relies on a discontinuous buffer system. Two ions differing in electrophoretic mobility (glycinate and chloride) form a moving boundary when voltage is applied. Proteins have an intermediate mobility that causes them to concentrate, or stack, into a narrow zone at the beginning of electrophoresis. As that zone moves through the gel, the sieving effect of the polyacrylamide gel matrix causes proteins of different molecular weights to move at different rates. This stacking effect is responsible for the high resolving power of SDS-PAGE: the sample is loaded in a relatively broad zone, and the moving boundary concentrates the proteins into sharp bands prior to separation.

Protein samples for SDS-PAGE are prepared using SDS and a thiol reducing agent, usually β -mercaptoethanol or dithiothreitol (DTT). SDS forms complexes with proteins, giving them a rodlike shape and similar mass-to-charge ratio. The reducing agent disrupts disulfide bonds between and within proteins, allowing complete denaturation and dissociation. Heat treatment in the presence of SDS and reducing agent effectively eliminates the effects of native charge and higher order structure on electrophoretic mobility, so the migration distance depends primarily on molecular weight.

Molecular weight is estimated by plotting the logarithm of protein molecular weight vs. the relative mobility (R_f) of the protein (R_f = distance migrated by the protein/distance migrated by the dye front) or by using the point-to-point semilog interpolation method in Quantity One® or Image Lab™ software. Refer to bulletins 3133, 3144, and 10014472 for more information.

3.2 Mini-PROTEAN TGX and Mini-PROTEAN® TGX Stain-Free™ Gels

Mini-PROTEAN TGX gels are Laemmli-like gels that have a proprietary modification that extends shelf life to 12 months and enhances separation characteristics relative to conventional gel types. They are run using standard Laemmli sample buffer and Tris/glycine/SDS running buffer, and they generate protein migration patterns that are similar to those observed with standard Laemmli Tris-HCl gels.

Two types of TGX formulations are available:

- Mini-PROTEAN TGX — Laemmli-like, extended shelf life gels
- Mini-PROTEAN TGX Stain-Free — Laemmli-like, extended shelf life gels with trihalo compounds that allow rapid fluorescent detection of proteins with the stain-free system, eliminating staining and destaining steps for faster results (see Chapter 5 for more details)

Both gel types gels are available in polyacrylamide single percentages and gradients. Use the protein migration charts and tables to select the gel type that optimizes resolution of your sample:

- Use single-percentage gels to separate bands of similar molecular weight. Optimum separation occurs in the lower half of the gel, so use a percentage in which the protein migrates to the lower half of the gel
- Use gradient gels to separate samples containing a broad range of molecular weights. Gradient gels allow resolution of both high- and low-molecular weight bands on the same gel. Larger pore sizes at the top of the gel permit resolution of larger molecules, smaller pore sizes toward the bottom of the gel restrict excessive separation of small molecules

Gel Composition

Crosslinker 2.6% C
 Stacking gel 4% T, 2.6% C
 Shelf life ~12 months at 2–8°C; expiration date is printed on package

Gel Percentage	Optimum Separation Range	Gel Percentage	Optimum Separation Range
7.5%	40–200 kD	4–15%	20–250 kD
10%	30–150 kD	4–20%	10–200 kD
12%	20–120 kD	Any kD™	10–100 kD



Migration charts for protein standards on Mini-PROTEAN TGX and Mini-PROTEAN TGX Stain-Free gels.

3.3 SDS-PAGE Buffers

See Appendix B for buffer formulations. Do not adjust pH.

- Running buffer (1x)** 25 mM Tris, 192 mM glycine, 0.1% SDS
Dilute 100 ml 10x stock (catalog #161-0732) with 900 ml deionized water (dH₂O).
- Sample buffer (2x)** 62.5 mM Tris-HCl, pH 6.8, 2% SDS, 25% (v/v) glycerol, 0.01% bromophenol blue, 5% β-mercaptoethanol or 100 mM DTT (added fresh)
Use Laemmli sample buffer (catalog #161-0737) and add β-mercaptoethanol or DTT before use.
- Sample buffer (4x)** 250 mM Tris-HCl, pH 6.8, 4% LDS, 40% (w/v) glycerol, 0.02% bromophenol blue, 15% beta-mercaptoethanol or 200 mM DTT (added fresh)
Use 4x Laemmli sample buffer (catalog #161-0747) and add β-mercaptoethanol or DTT before use.

3.4 Sample Preparation

- Determine the appropriate concentration of sample to load (depends on the load volume and the detection method used; see Chapter 10 for approximate stain sensitivities).
- Dilute the sample with sample buffer with added reducing agent.
 - 2x:** dilute 1 part sample with 1 part sample buffer.
 - 4x:** dilute 3 parts sample with 1 part sample buffer.

For nonreducing conditions, omit the reducing agent.
- Heat the diluted sample at 90–95°C for 5 min or at 70°C for 10 min.

3.5 Running Conditions

Run conditions and times are approximate. Run times represent the time required for the dye front to reach the line at the bottom of the cassette. Conditions may vary depending on water and buffer conductivity, which vary from one lab setting to the next. Multiply current by the number of gels run.

Table 3.1. Standard running conditions for SDS-PAGE in the Mini-PROTEAN Tetra cell.

Gel	Optimum Range	Run Conditions	Run Time
7.5%	40–200 kD	300 V constant: Starting current (per gel): 55–75 mA Final current (per gel): 45–70 mA	15–20 min (Fill outer buffer volume to the 4-gel mark)
10%	30–150 kD		
12%	20–120 kD		
4–15%	20–250 kD		
4–20%	10–200 kD		
Any kD	10–100 kD		

Table 3.2. Alternative running conditions for SDS-PAGE in the Mini-PROTEAN Tetra cell.

	100 V	200 V
Run time	85–95 min	30–40 min
Expected current (per gel)		
Initial	15–20 mA	25–50 mA
Final	5–10 mA	20–31 mA
Expected temperature	25°C	25–35°C
Outer buffer volume		
1–2 Gels	2-gel mark	2-gel mark
3–4 Gels	4-gel mark	4-gel mark

Table 3.3. PowerPac power supply recommendations.

# Gels	100 V	200 V	300 V
1–2	Basic/HC/HV/Universal	Basic/HC/HV/Universal	Basic/HV/Universal
3–4	Basic/HC/HV/Universal	Basic/HC/HV/Universal	HV/Universal
4–8	HC/HV/Universal	HC/HV/Universal	Universal
9–10	HC/Universal	HC/Universal	Universal
11–12	HC/Universal	HC/Universal	Universal

4

Native PAGE

4.1 Introduction

In native PAGE, proteins are prepared in nonreducing, nondenaturing sample buffer, which maintains native structure and mass-to-charge ratios. Separation is also performed in the absence of SDS and reducing agents. Though native PAGE uses the same moving boundary described for SDS-PAGE (see Section 3.1), protein mobility depends on a number of factors other than molecular weight, including the shape and charge of the protein. Protein-protein interactions may be retained during native PAGE, so some proteins may separate as multisubunit complexes. Consequently, native PAGE is not suitable for molecular weight determination.

The nonreducing and nondenaturing environment of native PAGE allows protein separation with retention of biological activity. Because native structure is retained, native PAGE can enable separation of proteins with the same molecular weight.

4.2 Mini-PROTEAN® TGX™ and Mini-PROTEAN® TGX Stain-Free™ Gels

Mini-PROTEAN TGX gels are Laemmli-like gels that have a proprietary modification that extends their shelf life to 12 months and enhances separation characteristics relative to conventional gel types. They are run using standard native sample buffer and Tris/glycine running buffer, and they generate protein migration patterns that are similar to those observed with standard Laemmli Tris-HCl gels.

Two types of TGX formulations are available:

- Mini-PROTEAN TGX — Laemmli-like, extended shelf life gels
- Mini-PROTEAN TGX Stain-Free — Laemmli-like, extended shelf life gels with trihalo compounds that allow rapid fluorescent detection of proteins with the stain-free system, eliminating staining and destaining steps for faster results (see Chapter 5 for more details)

These gels are available in a selection of polyacrylamide single percentages and gradients, and because they contain no SDS, they can be used for either SDS- or native PAGE applications.

Gel Composition

Crosslinker	2.6% C
Stacking gel	4% T, 2.6% C
Shelf life	~12 months at 2–8°C; expiration date is printed on the packaging

4.3 Native PAGE Buffers

See Appendix B for buffer formulations. Do not adjust pH.

Running buffer (1x)	25 mM Tris, 192 mM glycine Dilute 100 ml 10x stock (catalog #161-0734) with 900 ml diH ₂ O.
Sample buffer	62.5 mM Tris-HCl, pH 6.8, 40% (w/v) glycerol, 0.01% (w/v) bromophenol blue (catalog # 161-0738)

4.4 Sample Preparation

In the absence of SDS, the net charge of a polypeptide is determined by its amino acid composition and the pH of the gel during electrophoresis, which is a function of the sample buffer, gel buffer, and running buffer. Only polypeptides with a net negative charge migrate into gels under native conditions. Most polypeptides have an acidic or slightly basic pI (~3–8). These proteins can be separated using the following standard protocol:

1. Determine the desired protein concentration and load volume of your sample based on the detection method used (see Chapter 10 for approximate stain sensitivities).
2. Dilute the sample with an equal volume of native sample buffer (**do not heat the samples**).

For example, combine:

- 5 µl sample
- 5 µl native sample buffer (catalog #161-0738)
- 10 µl total volume

Strongly basic proteins (pI >8.5) have a net positive charge and will not enter a Mini-PROTEAN TGX gel under native conditions using Tris/glycine buffer. To allow polypeptides with a net positive charge to migrate into a native gel, change the polarity of the electrodes by reversing the color-coded jacks when connecting to the power supply.

4.5 Running Conditions

Running conditions for native PAGE are similar to the standard running conditions used for SDS-PAGE (Section 3.4). If elevated temperature is a concern, run native PAGE at lower voltage; at lower voltages, runs require more time to complete.

Table 4.1. Standard running conditions for native PAGE with one (1) gel in the Mini-PROTEAN Tetra cell. Run conditions and times are approximate and assume a constant voltage of 200 V. When running more than one gel, current will differ but temperature and run time should be close to those listed.

Gel	Current (mA) at 200 V		Temperature	Run Time
	Initial	Final		
1 Gel (buffer to 2-gel mark)				
7.5%	35–37	17–20	28–30°C	38–40 min
10%				
12%				
4–15%	50–55	25–28	30–33°C	30–34 min
4–20%				
Any kD				

5

Stain-Free System

5.1 Introduction

Bio-Rad's stain-free system eliminates the time-consuming staining and destaining steps required by other protein detection methods. Mini-PROTEAN® TGX Stain-Free™ gels include unique trihalo compounds that allow rapid fluorescent detection of proteins with stain free-enabled imaging systems — without staining.

The trihalo compounds in the gels react with tryptophan residues in a UV-induced reaction to produce fluorescence, which can be easily detected (by stain free-enabled imagers) within gels or on low-fluorescence PVDF membranes. Activation of the trihalo compounds in the gels adds 58 Da moieties to available tryptophan residues and is required for protein visualization. Proteins that do not contain tryptophan residues cannot be detected using this system. The sensitivity of the stain-free system is comparable to staining with Coomassie Brilliant Blue for proteins with a tryptophan content >1.5%; sensitivity superior to Coomassie staining is possible for proteins with a tryptophan content >3%.

Imaging systems that can be used with the stain-free system include the Gel Doc™ EZ and ChemiDoc™ MP systems (with Image Lab™ software).

Molecular weights of proteins can be estimated by a regression method using Image Lab software. The software generates a standard curve using the molecular weight and relative mobility (R_f) of standard proteins (R_f = distance migrated by the protein/distance migrated by the dye front). The standard curve is then used to estimate the molecular weights of sample proteins.

Benefits of the stain-free system include:

- Elimination of staining and destaining steps for faster results
- Automated gel imaging and analysis
- No background variability within a gel or between gels (as is often seen with standard Coomassie staining)
- Reduced organic waste by not requiring acetic acid and methanol for staining or destaining
- Visualization of transferred (blotted) proteins on low fluorescence PVDF membranes

5.2 Stain-Free Workflow

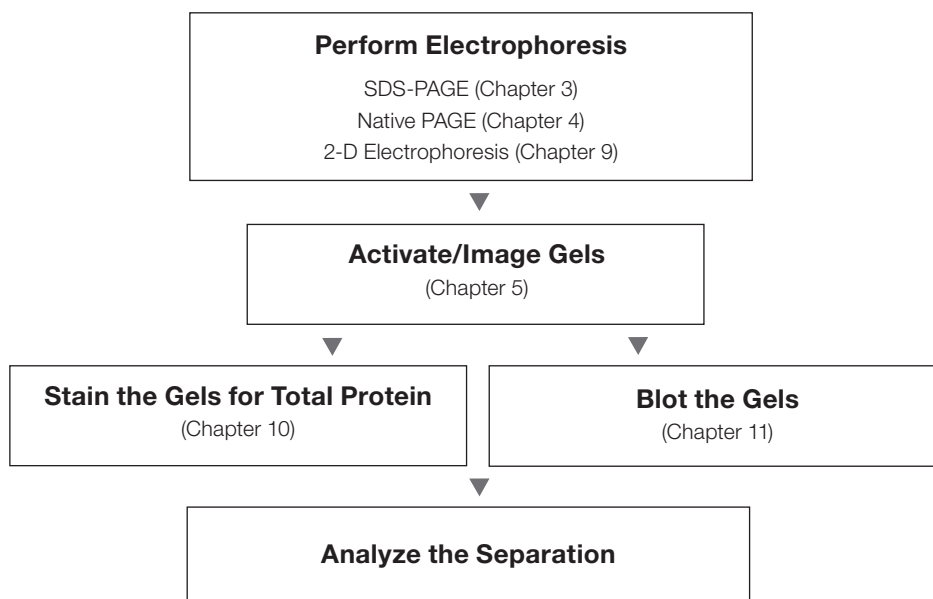

5.3 Electrophoresis with Mini-PROTEAN TGX Stain-Free Gels

Mini-PROTEAN TGX Stain-Free gels are made and packaged without SDS, so they can be used for both SDS and native PAGE applications. To perform electrophoresis with these gels, prepare the sample and running buffers, set up the Mini-PROTEAN Tetra cell, and perform the run as directed in Chapters 2–4.

Use unstained standards with Mini-PROTEAN TGX Stain-Free gels, as some prestained standards are not compatible with stain-free technology. To monitor electrophoresis, use 10 μ l of a 1:1 mixture of Precision Plus Protein™ unstained (catalog #161-0363) and Precision Plus Protein All Blue protein standards (catalog #161-0373).

5.4 Stain-Free Detection

Image Mini-PROTEAN TGX Stain-Free gels and blots in a compatible imager. The imager activates the reaction between the proteins and trihalo compounds in the gel to enable visualization.

- Immediately place the gel in the tray of the imager; no fixation or rinsing steps are required. Prolonged rinsing may diminish image quality and lead to gel deformation
- If desired, stain the gel with any TGX-compatible stains after imaging. Certain stains, if used prior to imaging, eliminate detection capability

Refer to the Gel Doc EZ Stain-Free Sample Tray Instruction Manual (bulletin 10019634) or the ChemiDoc MP System with Image Lab Software Instruction Manual (bulletin 10022469) for detailed instructions.

6

Peptide Analysis

6.1 Introduction

Mini-PROTEAN® Tris-Tricine peptide analysis gels are optimized for separating peptides and proteins with molecular weight <10,000. Peptide-SDS complexes move more slowly through these gels, allowing the faster SDS micelles, which normally interfere with peptide separations, to completely separate from peptides. This enables resolution of distinct peptide bands.

6.2 Mini-PROTEAN Tris-Tricine Gels

6.2.1 Gel Composition

Gel buffer	1.0 M Tris-HCl, pH 8.45
Crosslinker	2.6% C
Stacking gel	4% T, 2.6% C
Storage buffer	1.0 M Tris-HCl, pH 8.45, NaN ₃
Shelf life	12 weeks at 2–8°C; expiration date is printed on the packaging

6.2.2 Gel Selection Guide

Gel Percentage	Optimum Separation Range
16.5%	1.5–30 kD
10–20%	1–40 kD

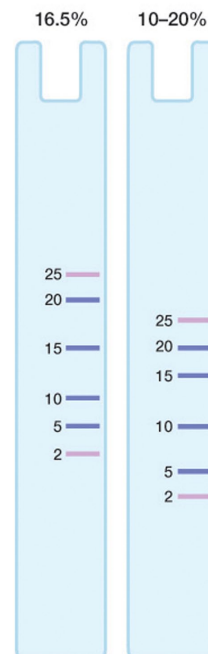

Migration charts for protein standards on Mini-PROTEAN Tris-Tricine gels.

6.3 Peptide Analysis Buffers

See Appendix B for buffer formulations. Do not adjust pH unless instructed to do so.

Running buffer (1x)	100 mM Tris, 100 mM Tricine, 0.1% SDS Dilute 100 ml 10x stock (catalog #161-0744) with 900 ml diH ₂ O
Sample buffer (catalog #161-0739)	200 mM Tris-HCl, pH 6.8, 2% SDS, 40% glycerol, 0.04% Coomassie Brilliant Blue G-250, 2% β-mercaptoethanol or 100 mM DTT (added fresh)

6.4 Sample Preparation

1. Determine the appropriate concentration of sample to load (depends on the load volume and the detection method used; see Chapter 10 for approximate stain sensitivities).
2. Dilute the sample with at least an equivalent volume of sample buffer (catalog #161-0739) and reducing agent (β-mercaptoethanol, for example). Heat the diluted sample at 90–95°C for 5 min, or at 70°C for 10 min.

For example, combine:

- 5 μl sample
- 4.75 μl Tricine sample buffer (catalog #161-0739)
- 0.25 μl β-mercaptoethanol (catalog #161-0710)
- 10 μl total volume

6.5 Running Conditions

Table 6.1. Running conditions for one (1) Mini-PROTEAN Tricine gel in the Mini-PROTEAN Tetra cell. Run conditions and times are approximate and assume a constant voltage of 100 V. When running more than one gel, current will differ.

	16.5% Gels	10–20% Gels
Power conditions	100 V constant	100 V constant
Expected current (per gel)		
Initial	65 mA	65 mA
Final	35 mA	35 mA
Run time	100 min	100 min

7

Nondenaturing Nucleic Acid PAGE

7.1 Introduction

Mini-PROTEAN® TBE gels are used to separate small double-stranded DNA (dsDNA) fragments, particularly PCR products. DNA molecules have nearly uniform mass-to-charge ratios, allowing nondenaturing nucleic acid PAGE to separate dsDNA by mass using a continuous TBE buffer system.

7.2 Mini-PROTEAN TBE Gels

7.2.1 Gel Composition

Gel buffer	89 mM Tris, 89 mM boric acid, 2 mM EDTA, pH 8.3
Crosslinker	3.3% C
Stacking gel	4% T, 3.3% C
Storage buffer	89 mM Tris, 89 mM boric acid, 2 mM EDTA, NaN ₃
Shelf life	12 weeks at 2–8°C; expiration date is printed on the packaging

7.2.2 Gel Selection Guide

Gel Percentage	Optimum Separation Range
5%	200–2,000 bp
10%	50–1,500 bp
15%	20–1,000 bp
4–20%	10–2,000 bp

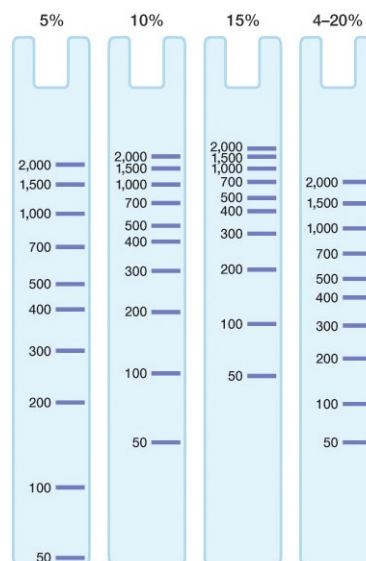

Migration charts for DNA standards on Mini-PROTEAN TBE gels.

7.3 Nondenaturing Nucleic Acid PAGE Buffers

See Appendix B for buffer formulations. Do not adjust pH unless directed to do so.

Running buffer (1x)	89 mM Tris, 89 mM boric acid, 2 mM EDTA Dilute 100 ml 10x stock (catalog #161-0733) with 900 ml diH ₂ O
Sample buffer (5x) (catalog #161-0767)	50 mM Tris-HCl, pH 8.0, 5 mM EDTA, 25% (w/v) glycerol, 0.2% bromophenol blue, 0.2% xylene cyanole FF

7.4 Sample Preparation

Determine the DNA concentration of your sample based on the detection method used. (See Chapter 10 for approximate stain sensitivities.) Dilute 4 parts sample with 1 part sample buffer.

7.5 Running Conditions

Table 7.1. Running conditions for nondenaturing nucleic acid PAGE with one (1) Mini-PROTEAN TBE gel in the Mini-PROTEAN Tetra cell. Run conditions and times are approximate and assume a constant voltage of 100 V. When running more than one gel, current will differ.

	5% Gels	10% Gels	15% Gels	4–20% Gels
Power conditions	100 V constant	100 V constant	100 V constant	100 V constant
Expected current (per gel)				
Initial	15 mA	15 mA	15 mA	15 mA
Final	10 mA	10 mA	10 mA	10 mA
Run time	45–60 min	60–75 min	75–90 min	90–105 min



Denaturing Nucleic Acid PAGE

8.1 Introduction

Mini-PROTEAN® TBE-urea gels are used for separation of small RNA and single-stranded DNA (ssDNA) fragments. Applications include oligonucleotide analysis, RNase protection assays, and northern blotting.

8.2 Mini-PROTEAN TBE-Urea Gels

8.2.1 Gel Composition

Gel buffer	89 mM Tris, 89 mM boric acid, 2 mM EDTA, 7 M urea, pH 8.3
Crosslinker	3.3% C
Stacking gel	4% T, 3.3% C
Storage buffer	89 mM Tris, 89 mM boric acid, 2 mM EDTA, pH 8.3, NaN ₃
Shelf life	8 weeks at 2–8°C; expiration date is printed on the packaging

8.2.2 Gel Selection Guide

Gel Percentage	Optimum Separation Range
10%	25–300 nt
15%	10–50 nt

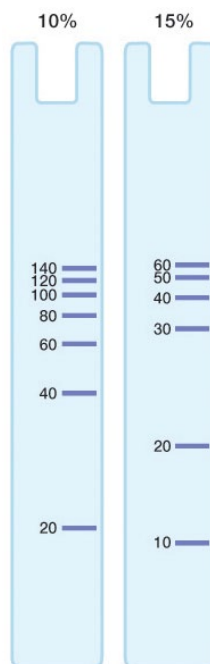

Migration charts for DNA standards on Mini-PROTEAN TBE-urea gels.

8.3 Denaturing Nucleic Acid PAGE Buffers

See Appendix B for buffer formulations. Do not adjust pH unless directed to do so.

Running buffer (1x)	89 mM Tris, 89 mM boric acid, 2 mM EDTA Dilute 100 ml 10x stock (catalog #161-0733) with 900 ml diH ₂ O
Sample buffer (5x) (catalog #161-0768)	89 mM Tris, 89 mM boric acid, 2 mM EDTA, pH 8.0, 12% Ficoll, 0.01% bromophenol blue, 0.02% xylene cyanole FF, 7 M urea

8.4 Sample Preparation

Determine the desired ssDNA or RNA concentration for your sample based on the detection method used. Dilute 4 parts sample with 1 part sample buffer.

8.5 Running Conditions

Table 8.1. Running conditions for denaturing nucleic acid PAGE with one (1) Mini-PROTEAN TBE-urea gel in the Mini-PROTEAN Tetra cell. Run conditions and times are approximate and assume a constant voltage of 200 V. When running more than one gel, current will differ.

	10% Gels	15% Gels
Power conditions	200 V constant	200 V constant
Expected current (per gel)		
Initial	15 mA	15 mA
Final	10 mA	10 mA
Run time	45–60 min	60–75 min

9

2-D Electrophoresis

9.1 Introduction

Mini-PROTEAN® precast gels are available for second-dimension PAGE in 2-D electrophoresis workflows. The IPG-well gels accommodate 7 cm IPG strips. Mini-PROTEAN® TGX Any kD™ gels are particularly well suited to 2-D electrophoresis applications.

The transition from first- to second-dimension gel electrophoresis involves:

- Equilibration of the resolved IPG strips in an SDS-containing, reducing buffer
- Placing the IPG strip on top of the second-dimension gel (agarose overlay)

9.2 Equilibration

Equilibration ensures that proteins in the IPG strips are coated with SDS and that cysteines are reduced and alkylated. Use the equilibration protocols (bulletin 411009) and buffers in the ReadyPrep™ 2-D starter kit (catalog #163-2105), or other protocols and buffers used for Tris-HCl gels.

9.3 Agarose Overlay

Place the equilibrated IPG strip into the IPG well of the gel and overlay it with molten agarose to ensure good contact between the strip and gel.

1. Prepare 0.5% low-melt agarose (catalog #161-3111), 0.003% bromophenol blue (catalog #161-0404) in 1x Tris/glycine/SDS running buffer (or use ReadyPrep overlay agarose, catalog #163-2111).
2. Following equilibration, place the IPG strip, gel side up, on the back plate of the gel, above the IPG well. The “+” and pH range on the IPG strip should be on the left.
3. Using forceps, push the strip into the IPG well, taking care to not trap air bubbles under the strip. Push on the backing of the strip, not on the gel.
4. Using a disposable pipet, apply overlay agarose into the IPG well. Fill the well to the top of the inner plate. Dispense rapidly, as overlay agarose solidifies quickly. To avoid bubbles, tilt the cassette slightly to allow bubbles to escape. Push gently on the plastic backings of the strip to free any trapped bubbles.

9.4 Second-Dimension Electrophoresis

Place the cassettes in to the Mini-PROTEAN® Tetra cell and start the run using the run conditions for SDS-PAGE. Use the migration of the bromophenol blue in the overlay agarose to monitor the progress of the run.

10 Detection

10.1 SDS-PAGE and Native PAGE Detection

Following electrophoresis, stain the gel with a total protein stain to visualize the proteins (Table 10.1).

Table 10.1. Total protein gel stains for use with Mini-PROTEAN gels.

Stain	Sensitivity (Lower Limit)	Optimum Protein Load (µg/Band)	Advantages	Disadvantages	Imaging	Manual
Mini-PROTEAN TGX Gels						
Coomassie R-250	36–47 ng	~0.5	Laboratory standard	Requires methanol destaining	Photography with white light or transmission densitometry	Consult literature
Bio-Safe™ Coomassie	8–28 ng	~0.5	Nonhazardous			4307051
Zinc stain ¹	6–12 ng	~0.2	High contrast, fast, reversible	Negative SDS-PAGE stain, must be photographed		4006082
Silver Stain Plus™ kit	0.6–1.2 ng	~0.01	Sensitive, robust, mass spectrometry compatible	Does not stain glycoproteins well		LIT442
Silver stain	0.6–1.2 ng	~0.01	Stains complex proteins (glyco- or lipoproteins)	Not mass spectrometry compatible		LIT34
Dodeca™ silver stain kit	0.5–1.2 ng	~0.1	Convenient staining for a large number of gels			4110150
Oriole™ fluorescent gel stain ¹	~2 ng	~0.1	High sensitivity, broad dynamic range, simple one-step protocol		Fluorescence visualization with UV trans-illumination	10017295
SYPRO Ruby protein gel stain	1–10 ng	~0.1	Broad dynamic range	Requires laser- or LED-based imaging instrument for maximum sensitivity	Fluorescence visualization with UV, LED, or laser scanning	4006173
Flamingo™ fluorescent gel stain	0.25–0.5 ng	~0.02	Broad dynamic range, mass spectrometry compatible			10003321
Stain-free imaging	2–28 ng	~0.5	Rapid (<5 min), compatible with blotting and mass spectrometry, simple protocol with no additional reagents	Requires tryptophan residues in proteins for detection	Fluorescence using stain-free compatible imaging system	10014472

¹Do not use zinc stain or Oriole fluorescent gel stain to stain native gels.

10.2 Peptide Gel Staining

Peptides and small proteins are prone to diffusion and loss during staining. The following protocol includes a fixing step prior to staining to prevent sample loss and is suitable for detection of bands as low as 10–20 ng.

Fixative solution	40% methanol, 10% acetic acid
Stain solution	0.025% (w/v) Coomassie Blue G-250, 10% acetic acid
Destain solution	10% acetic acid

Place gels in fixative solution and equilibrate for 30 min. Stain gels with stain solution for 1 hr. Stain should be used only once; reuse may result in loss of sensitivity. Destain gels three times for 15 min or until the desired background is achieved. Some peptides may not be completely fixed and may diffuse out of the gels if fixing and staining times are greatly exceeded.

10.3 TBE Gel Staining

Use Table 10.2 as a guide to selecting an appropriate staining method.

Table 10.2. TBE gel detection methods.

Method	Sensitivity (Lower Limit)	Advantages	Disadvantages
Ethidium bromide	50 ng	Classic fluorescent DNA stain	Carcinogenic
Silver stain	1–2 ng	More sensitive than ethidium bromide	Requires multiple steps
SYBR® Green	0.02–2 ng	High sensitivity	Multiple steps, –20°C storage
SYBR® Safe	0.5 ng	Non-hazardous	Multiple steps

10.4 TBE-Urea Gel Staining

Use Table 10.3 as a guide to selecting an appropriate staining method.

Table 10.3. TBE-urea gel detection methods.

Method	Sensitivity (Lower Limit)	Advantages	Disadvantages
Ethidium bromide	10 ng	Classic fluorescent DNA stain	Carcinogenic
SYBR® Green	0.02–2 ng	High sensitivity	Requires multiple steps, –20°C storage
Silver stain	1–2 ng	More sensitive than ethidium bromide	Requires multiple steps

11

Blotting

11.1 Introduction

Western blotting is an electrophoretic technique used to move proteins from a gel onto a solid support, such as a nitrocellulose or PVDF membrane. The membrane can be used for immunological or biochemical analyses or demonstration of protein-protein or protein-ligand interactions.

Below are guidelines for western blotting of Mini-PROTEAN® precast gels onto nitrocellulose or PVDF membranes using either wet or semi-dry transfer techniques. After transfer, assess transfer efficiency using a total protein blot stain (see Section 11.3); with Mini-PROTEAN® TGX Stain-Free™ gels, transfer efficiency to low fluorescence PVDF membranes may also be assessed using the Gel Doc™ EZ or ChemiDoc™ MP imager (see Chapter 5; activate the gel before blotting).

See Appendix B for buffer formulations. Do not adjust pH unless directed to do so.

11.2 Transfer

11.2.1 Transfer Buffers

Towbin buffer (1x) 25 mM Tris, 192 mM glycine, 20% (v/v) methanol (pH 8.3)
Dilute 100 ml 10x stock (catalog #161-0734) with 400 ml diH₂O.
Add 200 ml methanol, then adjust volume to 1 L with diH₂O.

Add SDS to 0.1% to promote transfer of high molecular weight proteins.

11.2.2 Wet Transfer Using the Mini Trans-Blot® Module

1. Equilibrate the gels in transfer buffer for 10–20 min prior to blot assembly.
2. Assemble the Mini Trans-Blot cassette. Place the gel closest to the black plate and the membrane closest to the red plate of the cassette. Use a roller to remove air trapped between the layers of the blot assembly.

Wet PVDF membranes in methanol before soaking in transfer buffer.

3. Place the assembled cassette into the transfer module and tank. The red cassette plate should face the red side of the transfer module. Repeat steps 2 and 3 for a second blot, if needed.
4. Add the cooling unit and stirbar, and fill the tank with transfer buffer. Place the tank on a stir plate, and begin stirring to maintain even buffer temperature and ion concentration during the transfer.
5. Connect the Mini Trans-Blot cell to a suitable power supply and begin transfer.

For many proteins, excellent transfer efficiency is obtained in 30 min at a constant voltage of 100 V. For best results, optimize conditions for proteins of interest. Large proteins (>150 kD) may take 60 min, while smaller proteins (<30 kD) may transfer in 20 min. Refer to the Mini Trans-Blot Instruction Manual (bulletin 1703910) or the Protein Blotting Guide (bulletin 2895) for additional information.

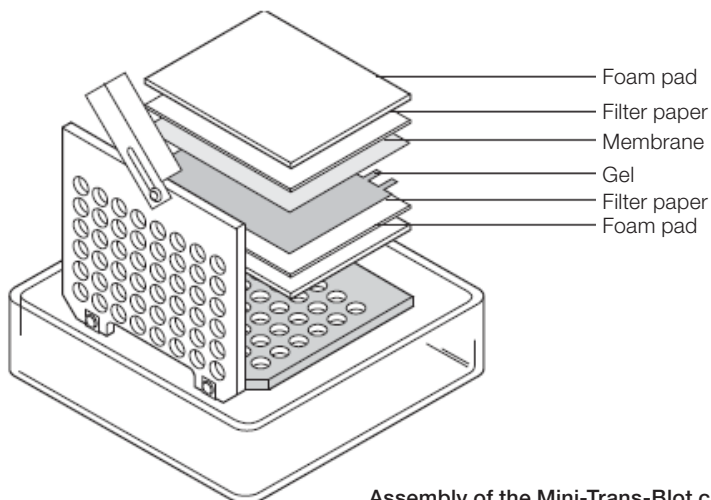

Assembly of the Mini-Trans-Blot cassette.

11.2.3 Transfer Using the Trans-Blot® Turbo™ System

1. Open the transfer pack and assemble the components on the cassette in the order shown. For best results, use the roller to remove any air trapped between the layers. If using a single mini or midi sandwich, place the sandwich in the middle of the cassette bottom. With two mini gels, place the sandwiches on a midi stack with the foot of each gel facing the center of the stack.
2. Place the lid on the cassette and lock the lid in place by turning the knob clockwise, using the symbols on the lid as a guide. Slide the cassette into the appropriate bay of the Trans-Blot Turbo cell. Each cassette and bay can hold up to two mini gels or one midi gel (Table 11.1).
3. Start the transfer. With the cassette in the cell, press TURBO and select the gel type. Press A:RUN or B:RUN to begin the transfer. Press LIST to select a Bio-Rad optimized protocol (Table 11.2) or a user-defined protocol. Press NEW to create and run a new protocol.
4. When transfer completes, RUN COMPLETE appears. Pull the cassette straight out of the slot and unlock the lid. Disassemble the blotting sandwich.

Refer to the Trans-Blot Turbo Instruction Manual (bulletin 10020688) for complete instructions.

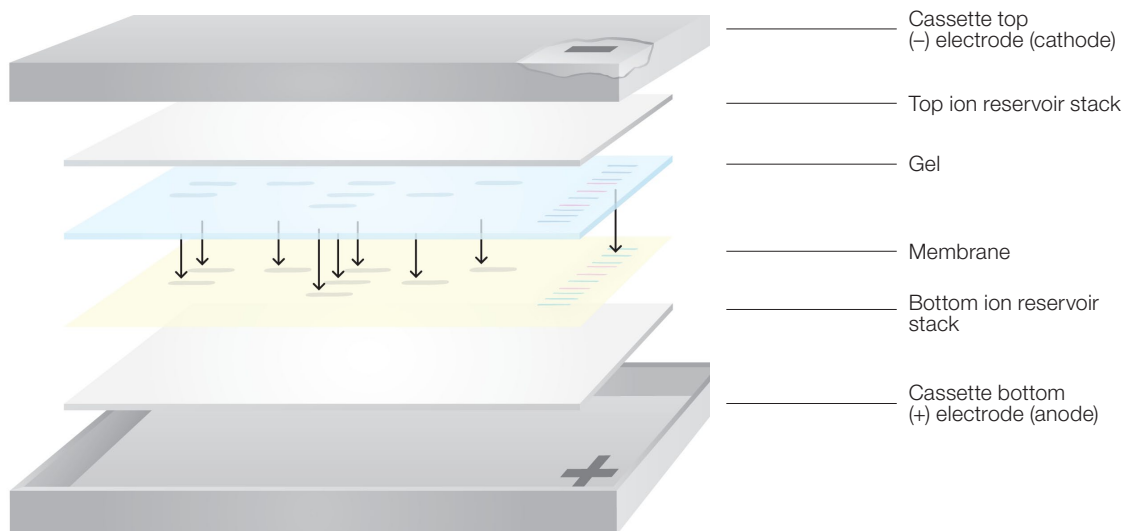

Assembly of the gel blot sandwich with the Trans-Blot Turbo system.

Table 11.1. Placement of cassettes in the Trans-Blot Turbo cell.

	Acceptable		Unacceptable	
	Option 1	Option 2	Option 1	Option 2
Upper bay (A)	1 mini gel -and/or-	2 mini gels -or- 1 midi gel -and/or-	1 mini gel -and-	2 mini gels -or- 1 midi gel -and-
Lower bay (B)	1 mini gel	2 mini gels -or- 1 midi gel	2 mini gels -or- 1 midi gel	1 mini gel

Table 11.2. Trans-Blot Turbo transfer protocols.

Protocol Name	MW, kD	Time, Min	1 Mini Gel	2 Mini Gels or 1 Midi Gel
STANDARD SD	Any	30	Up to 1.0 A, 25 V constant	Up to 1.0 A, 25 V constant
1.5 MM GEL	Any	10	2.5 A constant, up to 25 V	1.3 A constant, up to 25 V
HIGH MW	>150	10	2.5 A constant, up to 25 V	1.3 A constant, up to 25 V
LOW MW	<30	5	2.5 A constant, up to 25 V	1.3 A constant, up to 25 V
MIXED MW	5–150	7	2.5 A constant, up to 25 V	1.3 A constant, up to 25 V
1 Mini TGX	5–150	3	2.5 A constant, up to 25 V	N/A

11.2.4 Semi-Dry Transfer Using the Trans-Blot® SD Cell

1. Equilibrate the gels in transfer buffer for 10–20 min.
2. Assemble the blot for transfer using the Trans-Blot SD semi-dry transfer system.
3. Connect the Trans-Blot SD cell to a PowerPac™ Basic power supply and begin transfer at 25 V.

Optimum transfer efficiency is generally obtained in 30 min; smaller proteins (<30 kD) may transfer more quickly, while proteins >150 kD may show increased transfer efficiencies at up to 60 min. Run times longer than 60 min are NOT recommended for semi-dry transfers. Refer to the Trans-Blot SD Instruction Manual (bulletin 1703940) or the Protein Blotting Guide (bulletin 2895) for additional information.

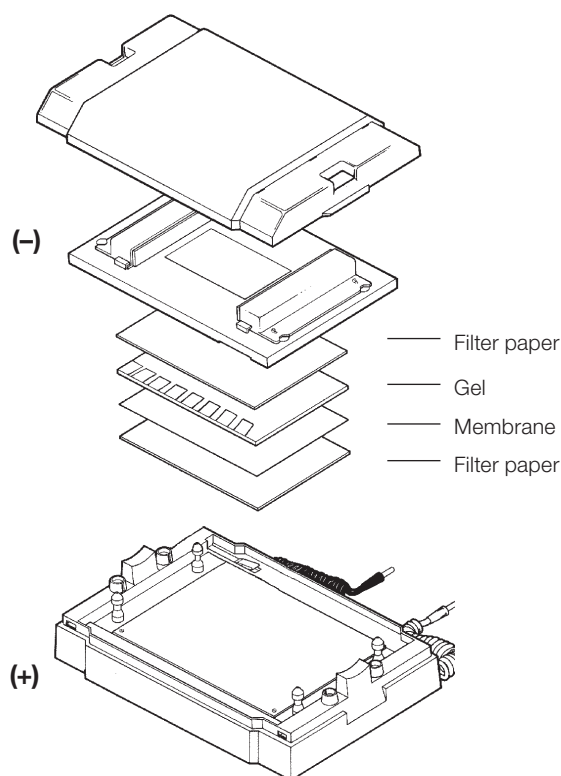
Assembly of the Trans-Blot SD semi-dry cell.

11.3 Total Protein Blot Stains

Total protein staining of a membrane provides an image of the complete protein pattern, which is required for the full characterization of specific antigens detected in complex protein mixtures. Gels shrink during staining, so comparison of an immunologically probed membrane to a stained gel is not practical. Instead, the exact location of a specific antigen is determined by comparing two blotted membranes: one that has been probed with an antibody and the other stained for total protein.

Table 11.3. Total protein blot stains.

Method	Sensitivity	Protein Load (µg/Band)	Advantages	Disadvantages	Imaging
SYPRO Ruby protein blot stain	2–8 ng	~0.2	Compatible with mass spectrometry, Edman-based sequencing, and standard immunological procedures	Multistep protocol requires UV, LED, or laser imaging for maximum sensitivity	Fluorescence visualization with UV, LED epi-illumination or laser scanning
Colloidal gold stain	1 ng	~0.1	High sensitivity; single-step protocol	Incompatible with nylon membranes	Photography with epi-illumination or reflectance densitometry
Anionic dyes (amido black, Coomassie R-250, Ponceau S, Fast Green FCF)	100–1,000 ng	~5.0	Inexpensive, rapid	Low sensitivity	Photography with epi-illumination or reflectance densitometry

To visualize total protein on blots using the stain-free system, see Section 5.4.

11.4 Immunodetection

After transfer, blots are ready for downstream processing. Though all protein and antibody combinations are different and may require optimization, a general protocol for immunodetection of a large number of protein and antibody combinations is listed below. See Appendix B for buffer formulations.

1. Immediately after transfer, place the membrane into Tris-buffered saline with Tween 20 (TTBS) containing blocking agent (for example, 3% BSA, 5% nonfat dry milk, 1% casein, or 1% gelatin) and incubate either for 1 hr at room temperature or overnight at 4°C.
2. Dilute the primary antibody in blocking solution (dilution is specified by the manufacturer). Incubate at room temperature with agitation for 1 hr.
3. Wash the blot with TTBS as directed (for example, five times, 5 min each at room temperature with agitation).
4. Dilute the secondary antibody into TTBS as specified by the manufacturer. Incubate the blot in the secondary solution at room temperature with agitation for 1 hr.
5. Wash the blot with TTBS five times, 5 min each at room temperature with agitation.
6. Follow the directions for the detection kit used to develop the blot. For the Immun-Star™ WesternC™ chemiluminescence kit (catalog #170-5070), mix 3 ml luminol/enhancer with 3 ml peroxide solution to make a 1x working solution for a 7 x 8.5 cm membrane. Incubate the membrane in the solution for 3–5 min. Prior to imaging, drain the excess substrate and place the membrane in a protective sleeve (such as plastic wrap) to prevent drying.

12 Troubleshooting

Table 12.1. Troubleshooting electrophoresis and detection with Mini-PROTEAN® gels. For more troubleshooting tips, refer to the relevant instrument instruction manuals or contact Technical Support.

Problem	Cause	Solution
Current is zero or less than expected, and samples do not migrate into gel	Tape at bottom of cassette not removed	Remove tape
	Insufficient buffer in inner buffer chamber	Fill buffer chamber with running buffer
	Insufficient buffer in outer buffer chamber	Fill inner and outer chambers to ensure wells of the gels are completely covered
	Incorrect cassette orientation	Ensure shorter plate is facing gasket
	Electrical disconnection	Check electrodes and connections
Gels run faster than expected	Running buffer too concentrated or incorrect	Check buffer composition
	Gel temperature too high	Do not exceed recommended running conditions
Gels run more slowly than expected	Companion running module left in tank when running only 1–2 gels	Remove companion running module
Buffer leaking from inner chamber	Incomplete gasket seal	Wet gasket with running buffer before use
	Improper assembly of the gel into the electrode/companion module	Top edge of short plate should fit under notch at top of gasket Top of short plate should touch green gasket
Bands “smile” across gel: band pattern curves upward at both sides of gel	Excessive heating of gel	Check buffer composition Do not exceed recommended running conditions
	Insufficient buffer	Fill inner and outer chambers to ensure wells of gels are completely covered
Bands “smile” or “frown” within gel lanes	Protein load too high	Load less protein
	Sample or buffer preparation issues	Minimize salts, detergents, and solvents in sample preparation and sample loading buffers
	Incorrect running conditions	Set correct voltage

Problem	Cause	Solution
Bands are skewed or distorted; lateral band spreading	Too much salt in samples	Remove salt from samples (dialysis, precipitation, or other method)
	Insufficient or wrong sample buffer	Check buffer composition and dilution
	Sample precipitation	Selectively remove predominant proteins Dilute sample in sample buffer
	Insoluble materials (for example, cell membranes) in samples	Centrifuge samples to remove particulates prior to sample loading
Artifactual bands at 60–70 kD	Skin keratin contamination	Clean all dishware; wear gloves while handling and loading gels Filter all solutions (0.2–0.45 µm filter)
Poor resolution or fuzzy bands	Sample volume is too high	If possible, load a more concentrated sample in a lower sample buffer volume
	Diffuse sample loading zone	Load sample with a syringe or gel loading pipet tip
	Sample diffusion during staining with Coomassie	Fix gel with 40% methanol, 10% acetic acid for 80 min prior to staining
	Incompatible sample components	Minimize salts, detergents, and solvents in sample preparation and loading buffers
	Expired gel	Use gels before expiration date on cassette

Mini-PROTEAN® TGX Stain-Free™ Gels

Low sensitivity for proteins	Low tryptophan content in proteins	After activation and imaging, stain gel with Bio-Safe™ Coomassie or similar to detect missing bands
Uneven sensitivity or fuzzy bands	Gel was soaked in water or buffer prior to activation and imaging	If possible, activate and image gel immediately after electrophoresis
Bands are too light or missing from blot (membrane)	Proteins transferred through membrane	Use membrane with smaller pore size Decrease transfer time Decrease voltage
Standards are not visible	Incorrect standards were used	Use unstained standards; some prestained standards are not detected by the imager. To monitor electrophoresis, use a 1:1 mixture of unstained and prestained standards
Dye front at bottom of gels interferes with detection of proteins	Sample constituents present in gel interfering with imaging	Dilute sample in gel running buffer prior to loading Activate and image gel, rinse in fixation solution for 30 min, and repeat imaging
Signal intensity on blot is lower than expected	Trihalo compounds bound to tryptophan residues inhibit binding of some antibodies	Blot gel without stain-free activation. If signal intensity is restored, use another (preferably polyclonal) antibody, if available
Sample bands are faint relative to prestained standards	Brightness of prestained standards can limit exposure times for sample bands	In Image Lab™ software, select Faint Bands to optimize exposure time or manually define longer exposure Adjust transform to optimize contrast for fainter bands



Quick Start Guides

This section contains abbreviated protocols (quick start guides) for the following electrophoretic techniques. Directions are for use of Mini-PROTEAN® precast gels and the Mini-PROTEAN® Tetra cell.

- SDS-PAGE using Mini-PROTEAN® TGX™ or Mini-PROTEAN® TGX Stain-Free™ precast gels
- Native PAGE using Mini-PROTEAN TGX or Mini-PROTEAN TGX Stain-Free precast gels
- Peptide analysis using Mini-PROTEAN Tris-Tricine gels
- Nondenaturing PAGE of nucleic acids using Mini-PROTEAN TBE gels
- Denaturing PAGE of nucleic acids using Mini-PROTEAN TBE-urea gels

SDS-PAGE (Mini-PROTEAN TGX Gels)

Prepare Buffers

Running buffer (1x) Dilute 100 ml 10x stock (catalog #161-0732) with 900 ml diH₂O.

Sample buffer Use Laemmli sample buffers: catalog #161-0737 or catalog #161-0747 (4x).



Prepare Gels and Assemble Electrophoresis Cell

Remove the comb and tape from the gels, rinse wells, and assemble the electrophoresis cell.

Fill the inner and outer buffer chambers with running buffer.



Prepare and Load Samples

Component	Reducing	Nonreducing
Sample	5 µl	5 µl
Laemmli sample buffer, 2x (catalog #161-0737)	4.75 µl	5 µl
β-Mercaptoethanol	0.25 µl	—
Total volume	10 µl	10 µl

Heat samples at 90–100°C for 5 min (or at 70°C for 10 min).

Load the appropriate amount of sample on the gel.



Perform Electrophoresis

Connect the electrophoresis cell to the power supply and perform electrophoresis according to the conditions in the table.

Table A.1. Running conditions for SDS-PAGE in the Mini-PROTEAN Tetra cell. Standard conditions are constant 300 V.

	100 V	200 V	300 V
Run time	85–95 min	30–40 min	15–20 min
Expected current (per gel)			
Initial	15–20 mA	25–50 mA	55–75 mA
Final	5–10 mA	20–31 mA	45–70 mA
Expected temperature	25°C	25–35°C	30–45°C
Outer buffer volume			
1–2 Gels	2-gel mark	2-gel mark	4-gel mark
3–4 Gels	4-gel mark	4-gel mark	4-gel mark ¹

¹ Requires the PowerPac™ HV or PowerPac Universal power supply.

Native PAGE (Mini-PROTEAN TGX Gels)

Prepare Buffers

Running buffer (1x) Dilute 100 ml 10x stock (catalog #161-0734) with 900 ml diH₂O.

Sample buffer Use native sample buffer (catalog #161-0738)



**Prepare Gels and
Assemble Electrophoresis Cell**

Remove the comb and tape from the gels, rinse wells, and assemble the electrophoresis cell.

Fill the inner and outer buffer chambers with running buffer.



Prepare and Load Samples

Component	Volume
Sample	5 µl
Native sample buffer (catalog #161-0738)	5 µl
Total volume	10 µl

Load the appropriate amount of sample on the gel.



Perform Electrophoresis

Connect the electrophoresis cell to the power supply and perform electrophoresis according to the conditions in the table.

Table A.2. Standard running conditions for native PAGE with one (1) Mini-PROTEAN TGX gel in the Mini-PROTEAN Tetra cell. Run conditions and times are approximate and assume a constant voltage of 200 V. When running more than one gel, current will differ but temperature and run time should be close to those listed.

Gel	Current (mA) at 200 V		Temperature	Run Time
	Initial	Final		
1 Gel (buffer to 2-gel mark)				
7.5%	35–37	17–20	28–30°C	38–40 min
10%				
12%				
4–15%	50–55	25–28	30–33°C	30–34 min
4–20%				
Any kD™				

Peptide Analysis (Mini-PROTEAN Tris-Tricine Gels)

Prepare Buffers

Running buffer (1x) Dilute 100 ml 10x stock (catalog #161-0744) with 900 ml diH₂O.

**Sample buffer (2x)
(catalog #161-0739)** 200 mM Tris-HCl, pH 6.8, 2% SDS, 40% glycerol, 0.04% Coomassie Brilliant Blue G-250, 2% β-mercaptoethanol or 350 mM DTT (added fresh)



Prepare Gels and Assemble Electrophoresis Cell

Remove the comb and tape from the gels and assemble the electrophoresis cell.

Fill the inner and outer buffer chambers with running buffer.



Prepare and Load Samples

Component	Reducing	Nonreducing
Sample	5 µl	5 µl
Sample buffer (catalog #161-0739)	4.75 µl	5 µl
β-Mercaptoethanol	0.25 µl	—
Total volume	10 µl	10 µl

Heat samples at 90–100°C for 5 min or at 70°C for 10 min.

Load the appropriate amount of sample on the gel.



Perform Electrophoresis

Connect the electrophoresis cell to the power supply and perform electrophoresis according to the conditions in the table.

Table A.3. Running conditions for one (1) Mini-PROTEAN Tricine gel in the Mini-PROTEAN Tetra cell. Run conditions and times are approximate and assume a constant voltage of 100 V. When running more than one gel, current will differ.

	16.5% Gels	10–20% Gels
Power conditions	100 V constant	100 V constant
Expected current (per gel)		
Initial	65 mA	65 mA
Final	35 mA	35 mA
Run time	100 min	100 min

Nondenaturing Nucleic Acid PAGE (Mini-PROTEAN TBE Gels)

Prepare Buffers

Running buffer (1x) Dilute 100 ml 10x stock (catalog #161-0733) with 900 ml diH₂O.

**Sample buffer (5x)
(catalog #161-0767)** 50 mM Tris-HCl, pH 8.0, 5mM EDTA, 25% glycerol, 0.2% bromophenol blue, 0.2% xylene cyanole FF



Prepare Gels and Assemble Electrophoresis Cell

Remove the comb and tape from the gels and assemble the electrophoresis cell.

Fill the inner and outer buffer chambers with running buffer.



Prepare and Load Samples

Component	Amount
Sample	8 µl
Sample buffer (catalog #161-0767)	2 µl
Total volume	10 µl

Load the appropriate amount of sample on the gel.



Perform Electrophoresis

Connect the electrophoresis cell to the power supply and perform electrophoresis according to the conditions in the table.

Table A.4. Running conditions for nondenaturing nucleic acid PAGE with one (1) Mini-PROTEAN TBE gel in the Mini-PROTEAN Tetra cell. Run conditions and times are approximate and assume a constant voltage of 100 V. When running more than one gel, current will differ.

	5% Gels	10% Gels	15% Gels	4–20% Gels
Power conditions	100 V constant	100 V constant	100 V constant	100 V constant
Expected current (per gel)				
Initial	15 mA	15 mA	15 mA	15 mA
Final	10 mA	10 mA	10 mA	10 mA
Run time	45–60 min	60–75 min	75–90 min	90–105 min

Denaturing Nucleic Acid PAGE (Mini-PROTEAN TBE-Urea Gels)

Prepare Buffers

- Running buffer (1x)** Dilute 100 ml 10x stock (catalog #161-0733) with 900 ml diH₂O.
- Sample buffer (5x)
(catalog #161-0768)** 89 mM Tris, 89 mM boric acid, 2 mM EDTA, pH 8.0, 12% Ficoll, 0.01% bromophenol blue, 0.02% xylene cyanole FF, 7 M urea



Prepare Gels and Assemble Electrophoresis Cell

Remove the comb and tape from the gels and assemble the electrophoresis cell.

Fill the inner and outer buffer chambers with running buffer.



Prepare and Load Samples

Component	Amount
Sample	8 µl
Sample buffer (catalog #161-0768)	2 µl
Total volume	10 µl

Load the appropriate amount of sample on the gel.



Perform Electrophoresis

Connect the electrophoresis cell to the power supply and perform electrophoresis according to the conditions in the table.

Table A.5. Running conditions for denaturing nucleic acid PAGE with one (1) Mini-PROTEAN TBE-urea gel in the Mini-PROTEAN Tetra cell. Run conditions and times are approximate and assume a constant voltage of 200 V. When running more than one gel, current will differ.

	10% Gels	15% Gels
Power conditions	200 V constant	200 V constant
Expected current (per gel)		
Initial	15 mA	15 mA
Final	10 mA	10 mA
Run time	45–60 min	60–75 min



Buffers

Running Buffers

10x SDS-PAGE (1 L)
(catalog #161-0732)

250 mM Tris, 1.92 M glycine, 1% SDS, pH 8.3

Tris base	30.3 g
Glycine	144.1 g
SDS	10 g
diH ₂ O	to 1 L

Do not adjust the pH (~pH 8.3)

10x Native PAGE (1 L)
(catalog #161-0734)

250 mM Tris, 1.92 M glycine, pH 8.3

Tris base	30.3 g
Glycine	144.1 g
diH ₂ O	to 1 L

Do not adjust the pH (~pH 8.3)

10x Tris-Tricine (1 L)
(catalog #161-0744)

1 M Tris, 1 M Tricine, 1% SDS, pH 8.3

Tris base	121.1 g
Tricine	179.2 g
SDS	10 g
diH ₂ O	to 1 L

Do not adjust the pH (~pH 8.3)

10x TBE (1 L)
(catalog #161-0741)

890 mM Tris, 890 mM boric acid, 20 mM EDTA

Tris base	107.8 g
Boric acid	55.0 g
EDTA	5.8 g
diH ₂ O	to 1 L

Do not adjust the pH (~pH 8.3)

Sample Buffers

2x SDS-PAGE (Laemmli, 30 ml)
(catalog #161-0737)

62.5 mM Tris-HCl, pH 6.8, 2% SDS, 25% glycerol, 0.01% bromophenol blue, 5% β -mercaptoethanol (added fresh)

0.5 M Tris-HCl, pH 6.8	3.75 ml
50% Glycerol	15.0 ml
1.0% Bromophenol blue	0.3 ml
10% SDS	6.0 ml
diH ₂ O	to 30 ml

Add β -mercaptoethanol (50 μ l to 950 μ l sample buffer) before use.

2x Native PAGE (30 ml)
(catalog #161-0738)

62.5 mM Tris-HCl, pH 6.8, 40% glycerol, 0.01% bromophenol blue

0.5 M Tris-HCl, pH 6.8	3.75 ml
50% Glycerol	24 ml
1.0% Bromophenol blue	0.3 ml
diH ₂ O	to 30 ml

2x Tricine (30 ml)
(catalog #161-0739)

200 mM Tris-HCl, pH 6.8, 2% SDS, 40% glycerol, 0.04% Coomassie Brilliant Blue G-250, 2% β -mercaptoethanol (added fresh)

1.0 M Tris-HCl, pH 6.8	6.0 ml
100% Glycerol	12.0 ml
10% SDS	6.0 ml
Coomassie Blue G-250	12.0 mg
diH ₂ O	to 30 ml

Add β -mercaptoethanol (20 μ l to 980 μ l sample buffer) before use.

5x Nucleic acid (10 ml)
(catalog #161-0767)

50 mM Tris-HCl, pH 8.0, 5 mM EDTA, 25% glycerol, 0.2% bromophenol blue, 0.2% xylene cyanole FF

Tris base	78.8 mg
50% Glycerol	5 ml
EDTA	14.6 mg
1.0% Bromophenol blue	2.0 ml
Xylene cyanole FF	20.0 mg
diH ₂ O	to 10 ml

TBE-urea (30 ml)
 (catalog #161-0768)
 Store at 4°C

89 mM Tris, 89 mM boric acid, 2 mM EDTA, pH 8.0, 12% Ficoll, 0.01% bromophenol blue, 0.02% xylene cyanole, 7 M urea

Tris base	0.32 g
Boric acid	0.165 g
EDTA	17.5 mg
Ficoll	3.6 g
Bromophenol blue	3 mg
Xylene cyanole FF	6 mg
Urea	12.6 g
diH ₂ O	to 30 ml

Buffer Components

0.5 M Tris-HCl, pH 6.8 (1 L)
 (catalog #161-0799)
 Store at 4°C

Tris base	60.6 g
diH ₂ O	~900 ml
Adjust to pH 6.8 with HCl	
diH ₂ O	to 1 L

10% SDS (250 ml)
 (catalog #161-0416)

SDS	25.0 g
diH ₂ O	to 250 ml

1.0% Bromophenol blue (10 ml)
 (10 g powder, catalog #161-0404)

Bromophenol blue	100 mg
diH ₂ O	to 10 ml

Blotting Buffers

Towbin buffer (1 L)

Dissolve:

25 mM Tris, 192 mM glycine, 20% methanol

Tris base	3.03 g
Glycine	14.4 g
diH ₂ O	500 ml

Then add:

Methanol	200 ml
diH ₂ O	to 1 L

Alternatively, use:

10x Tris/glycine (catalog #161-0734) 100 ml
 Add 200 ml methanol and diH₂O to 1 L as above

Tris-buffered saline with Tween (TTBS, 1 L)

20 mM Tris, 500 mM NaCl, 0.05% Tween 20

Tris base	2.4 g
NaCl	29.2 g
10% Tween 20	5.0 ml
diH ₂ O	to 1 L

Alternatively, use:

10x TBS (catalog #170-6435)	100 ml
10% Tween 20 (catalog #166-2404)	5 ml
diH ₂ O	895 ml



Related Literature

Bulletin #	Title
10007296	Mini-PROTEAN® Tetra Cell Instruction Manual
4006191	Mini-PROTEAN® 3 Dodeca™ Cell Instruction Manual
1703930	Mini Trans-Blot® Instruction Manual
10020688	Trans-Blot® Turbo™ Blotting System Instruction Manual
4006066	Trans-Blot® SD Semi-Dry Transfer Cell Quick Reference Guide
1703940	Trans-Blot SD Semi-Dry Transfer Cell Instruction Manual
10014472	Gel Doc™ EZ System Installation Guide
10019634	Stain-Free™ Sample Tray Instruction Manual
10022469	ChemiDoc™ MP System with Image Lab Software Instruction Manual
5871	Mini-PROTEAN® TGX™ Precast Gels Product Information Sheet
5535	Mini-PROTEAN Tetra Cell Brochure
2895	Protein Blotting Guide
3133	Molecular Weight Determination by SDS-PAGE
3144	Using Precision Plus Protein™ Standards to Determine Molecular Weight
6088	Bio-Rad V3 Western Workflow™ Brochure
1939	Blotting Membrane Brochure
6116	Immun-Blot® LF PVDF Membranes Product Information Sheet
2032	Western Blotting Detection Reagent Brochure
2317	Ready-to-Run Buffers and Solutions Brochure
2414	The Little Book of Standards



Ordering Information

Mini-PROTEAN® TGX™ Precast Gels

	8+1 Well	10-Well	12-Well	15-Well	IPG/Prep	
	(30 µl/well)	(30 µl/well)	(50 µl/well)	(20 µl/well)	(15 µl/well)	
					7 cm IPG strip (450 µl/well)	
10 Gels per Box						
7.5%	456-1029	456-1023	456-1024	456-1025	456-1026	456-1021
10%	456-1039	456-1033	456-1034	456-1035	456-1036	456-1031
12%	456-1049	456-1043	456-1044	456-1045	456-1046	456-1041
4–15%	456-1089	456-1083	456-1084	456-1085	456-1086	456-1081
4–20%	456-1099	456-1093	456-1094	456-1095	456-1096	456-1091
8-16%	456-1109	456-1103	456-1104	456-1105	456-1106	456-1101
Any kD™	456-9039	456-9033	456-9034	456-9035	456-9036	456-9031

Mini-PROTEAN® TGX Stain-Free™ Precast Gels

	8+1 Well	10-Well	12-Well	15-Well	IPG/Prep	
	(30 µl/well)	(30 µl/well)	(50 µl/well)	(20 µl/well)	(15 µl/well)	
					7 cm IPG strip (450 µl/well)	
10 Gels per Box						
7.5%	456-8029	456-8023	456-8024	456-8025	456-8026	456-8021
10%	456-8039	456-8033	456-8034	456-8035	456-8036	456-8031
12%	456-8049	456-8043	456-8044	456-8045	456-8046	456-8041
4–15%	456-8089	456-8083	456-8084	456-8085	456-8086	456-8081
4-20%	456-8099	456-8093	456-8094	456-8095	456-8096	456-8091
8-16%	456-8109	456-8103	456-8104	456-8105	456-8106	456-8101
Any kD	456-8129	456-8123	456-8124	456-8125	456-8126	546-8121

Note: Mini-PROTEAN TGX and TGX Stain-Free gels are available in 10-packs (catalog numbers listed) or 2-packs (add an "S" to the end of the catalog number listed).

Mini-PROTEAN Tris-Tricine Precast Gels

	2 Gels per Box		
	10-Well		15-Well
	(30 µl/well)	(50 µl/well)	(15 µl/well)
16.5%	456-3063	456-3064	456-3066
10–20%	456-3113	456-3114	456-3116

Mini-PROTEAN TBE-Urea Precast Gels

	2 Gels per Box	
	10-Well	15-Well
	(30 µl/well)	(15 µl/well)
10%	456-6033	456-6036
15%	456-6053	456-6056

Mini-PROTEAN TBE Precast Gels

	2 Gels per Box				2 Gels per Box		
	10-Well		15-Well		10-Well		15-Well
	(30 µl/well)	(50 µl/well)	(15 µl/well)		(30 µl/well)	(50 µl/well)	(15 µl/well)
5%	456-5013	456-5014	456-5016	15%	456-5053	456-5054	456-5056
10%	456-5033	456-5034	456-5036	4–20%	456-5093	456-5094	456-5096

Catalog # Description

Protein Standards

- 161-0363 Precision Plus Protein™ Unstained Standards (10–250 kD), 1 ml, 100 applications
- 161-0373 Precision Plus Protein All Blue Standards (10–250 kD), 500 µl, 50 applications
- 161-0374 Precision Plus Protein Dual Color Standards (10–250 kD), 500 µl, 50 applications
- 161-0375 Precision Plus Protein™ Kaleidoscope™ Standards (10–250 kD), 500 µl, 50 applications
- 161-0376 Precision Plus Protein™ WesternC™ Standards (10–250 kD), 250 µl, 50 applications
- 161-0377 Precision Plus Protein Dual Xtra Standards (2–250 kD), 500 µl, 50 applications
- 161-0385 Precision Plus Protein WesternC Pack (10–250 kD), 50 applications
- 161-0317 SDS-PAGE Standards, broad range, 200 µl

Equipment

- 165-8004 Mini-PROTEAN® Tetra Cell for Ready Gel™ Precast Plates (4-gel system)
- 165-8005 Mini-PROTEAN Tetra Cell for Ready Gel Precast plates (2-gel system)
- 165-4100 Mini-PROTEAN® 3 Dodeca™ Cell
- 170-3930 Mini Trans-Blot® Electrophoretic Transfer Cell
- 170-3940 Trans-Blot® SD Semi-Dry Electrophoretic Transfer Cell
- 170-4155 Trans-Blot® Turbo™ Transfer Starter System
- 164-5050 PowerPac™ Basic Power Supply
- 164-5052 PowerPac HC High Current Power Supply
- 170-8270 Gel Doc™ EZ Imaging System
- 170-8274 Stain-Free™ Sample Tray
- 170-8280 ChemiDoc™ MP Imaging System with Image Lab™ Software

Catalog #	Description
Premixed Running Buffers	
161-0732	10x Tris/Glycine/SDS, 1 L
161-0772	10x Tris/Glycine/SDS, 5 L
161-0734	10x Tris/Glycine, 1 L
161-0744	10x Tris/Tricine/SDS, 1 L
161-0733	10x Tris/Boric Acid/EDTA, 1 L
161-0770	10x Tris/Boric Acid/EDTA, 5 L
Premixed Sample Buffers	
161-0737	Laemmli Sample Buffer, 30 ml*
161-0747	4x Laemmli Sample Buffer, 10 ml*
161-0738	Native Sample Buffer, 30 ml
161-0739	Tricine Sample Buffer, 30 ml
161-0767	Nucleic Acid Sample Buffer, 5x, 10 ml
161-0768	TBE-Urea Sample Buffer, 30 ml
Component Reagents	
161-0719	Tris, 1 kg
161-0718	Glycine, 1 kg
161-0301	SDS, 100 g
161-0416	SDS Solution, 10% (w/v), 250 ml
166-2404	10% Tween 20, 5 ml
170-6404	Blotting-Grade Blocker, 300 g
161-0710	2-mercaptoethanol, 25 ml
161-0611	Dithiothreitol, 5 g
161-0404	Bromophenol Blue, 10 g
Blotting Membranes	
162-0212	0.2 µm Nitrocellulose/Filter Paper Sandwich, 7 x 8.5 cm, 20 pack
162-0213	0.2 µm Nitrocellulose/Filter Paper Sandwich, 7 x 8.5 cm, 50 pack
162-0214	0.45 µm Nitrocellulose/Filter Paper Sandwich, 7 x 8.5 cm, 20 pack
162-0215	0.45 µm Nitrocellulose/Filter Paper Sandwich, 7 x 8.5 cm, 50 pack
162-0216	Sequi-Blot™ PVDF/Filter Paper Sandwich, 7 x 8.5 cm, 20 pack
162-0217	Sequi-Blot PVDF/Filter Paper Sandwich, 7 x 8.5 cm, 50 pack
170-4156	Trans-Blot Turbo Midi PVDF Transfer Packs
170-4158	Trans-Blot Turbo Midi Nitrocellulose Transfer Packs
162-0260	Immun-Blot® Low Fluorescence PVDF/Filter Paper Sets, 10 pack
162-0261	Immun-Blot Low Fluorescence PVDF/Filter Paper Sets, 20 pack
162-0264	Immun-Blot Low Fluorescence PVDF Membrane

* May require addition of 2-mercaptoethanol or DTT

■ Mini-PROTEAN Precast Gels

Catalog #	Description
Total Protein Gel and Blot Stains	
161-0786	Bio-Safe™ Coomassie Stain, 1 L
161-0400	Coomassie Brilliant Blue R-250, 10 g
161-0436	Coomassie Brilliant Blue R-250 Stain Solution, 1 L
161-0438	Coomassie Brilliant Blue R-250 Destain Solution, 1 L
161-0443	Silver Stain Kit
161-0449	Silver Stain Plus™ Kit
170-6527	Colloidal Gold Total Protein Stain, 500 ml
161-0440	Zinc Stain and Destain Kit
170-3127	SYPRO Ruby Protein Blot Stain, 200 ml
161-0491	Flamingo™ Fluorescent Gel Stain (10x), 100 ml
161-0496	Oriole™ Fluorescent Protein Gel Stain (1x), 1 L

Immunoblot Detection Reagents

170-5070	Immun-Star™ WesternC™ Chemiluminescent Kit, 100 ml
170-6431	HRP Conjugate Substrate Kit, 4CN
170-6535	HRP Color Development Reagent, DAB, 5 g
170-8238	Amplified Opti-4CN™ Substrate Kit
170-8235	Opti-4CN Substrate Kit
170-6432	AP Conjugate Substrate Kit
170-5012	Immun-Star™ AP Substrate Pack

For additional product sizes, please refer to the Bio-Rad catalog or website.

000 «Диаэм»

Москва

ул. Магаданская, д. 7, к. 3 ■ тел./факс: (495) 745-0508 ■ sales@dia-m.ru

www.dia-m.ru

С.-Петербург

+7 (812) 372-6040
spb@dia-m.ru

Новосибирск

+7 (383) 328-0048
nsk@dia-m.ru

Воронеж

+7 (473) 232-4412
vrn@dia-m.ru

Йошкар-Ола

+7 (927) 880-3676
nba@dia-m.ru

Красноярск

+7 (923) 303-0152
krsk@dia-m.ru

Казань

+7 (843) 210-2080
kazan@dia-m.ru

Ростов-на-Дону

+7 (863) 303-5500
rnd@dia-m.ru

Екатеринбург

+7 (912) 658-7606
ekb@dia-m.ru

Кемерово

+7 (923) 158-6753
kemerovo@dia-m.ru

Армения

+7 (094) 01-0173
armenia@dia-m.ru

